

SHIVER DH Race

(upper plate)

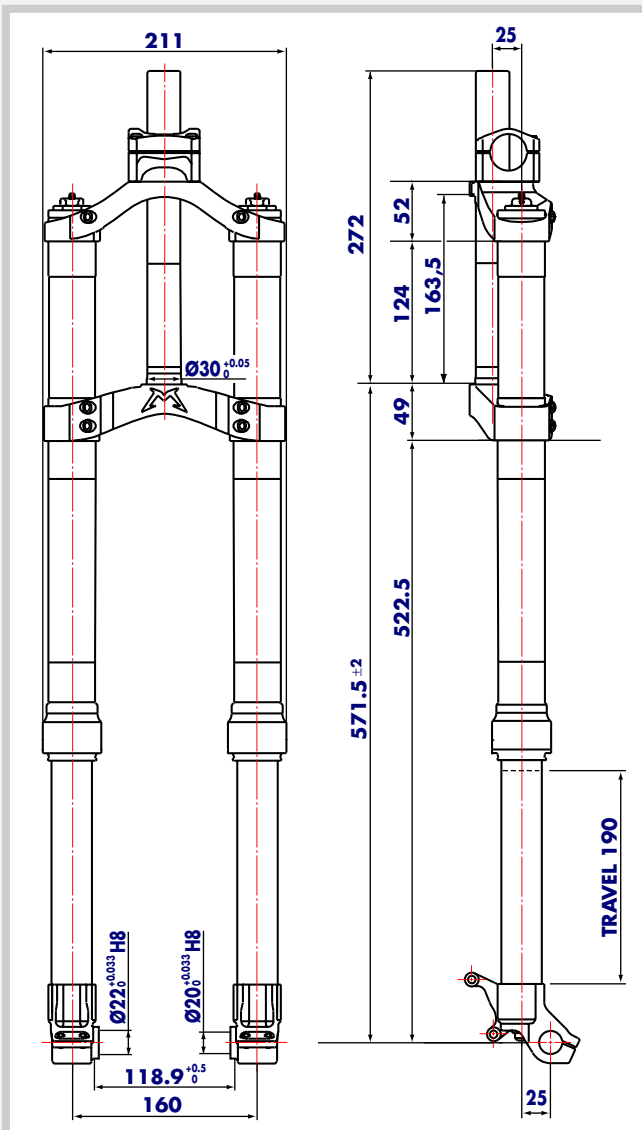

GENERAL

- The upside down-leg double plate fork is specifically designed for Downhill use. Damped by hydraulic cartridges and sprung by a mechanical coil spring system.
- Cartridge inside each fork leg works during rebound, each cartridge has a rebound spring to counteract limit position stop action.
- Spring pre-load and rebound damping adjustment controlled via external top mount adjusters.
- Stanchions are integral with wheel shaft pinch bolts.
- Outer sliders secured to the crown and upper crown. The system gives the fork unmatched structural strength.
- Stanchions are guided by special long-life bushes inside the sliders. Bushes can be easily reached for servicing.
- Parts subjected to friction are cooled and lubricated by specially formulated oil.
- Left wheel shaft pinch bolt comes with brake caliper adapter.
- Axle support is the same drop-out design as in motorbikes, having advanced wheel shaft with twin screw securing wheel shaft onto both wheel shaft pinch bolts.
- Wheel shaft (20 mm diam.) available on request.
- Adjustable handlebar support onto upper crown.

Steer tube: EASTON aluminum steer tubes or steel tube available for 1 1/8", threadless.

Crown: Forged and CNC-machined aluminum alloy.

Upper crown: Forged and CNC-machined aluminum alloy. Two versions available for different frame sizes.

Handlebar support: Forged and CNC-machined aluminum alloy. Advanced handlebar axle model also available.

Stanchions: Anodized EASTON aluminum.

Feet: Forged and CNC-machined aluminum alloy.

Springs: worm springs with steady pitch.

Sliders: CNC-machined aluminum alloy.

Slider bushing: composed of a copper base and impregnated with an anti-friction coating.

Seals: Computer designed oil seals and dust seals guarantee the highest quality seals available.

Oil: Specially formulated oil which eliminates foaming and viscosity breakdown while providing complete stiction-free performance.

Fork leg oil: 300 cc, type EBH 16- SAE 7.5.

SHIVER DH Race

(lower plate)

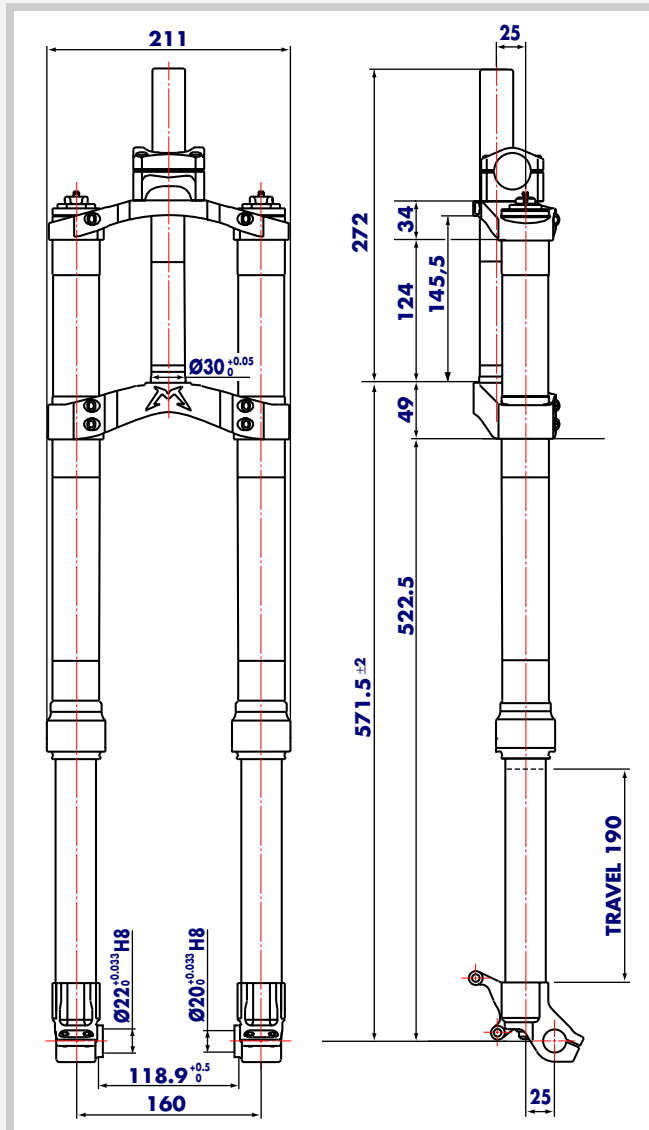

GENERAL

- The upside down-leg double plate fork is specifically designed for Downhill use. Damped by hydraulic cartridges and sprung by a mechanical coil spring system.
- Cartridge inside each fork leg works during rebound, each cartridge has a rebound spring to counteract limit position stop action.
- Spring pre-load and rebound damping adjustment controlled via external top mount adjusters.
- Stanchions are integral with wheel shaft pinch bolts.
- Outer sliders secured to the crown and upper crown. The system gives the fork unmatched structural strength.
- Stanchions are guided by special long-life bushes inside the sliders. Bushes can be easily reached for servicing.
- Parts subjected to friction are cooled and lubricated by specially formulated oil.
- Left wheel shaft pinch bolt comes with brake caliper adapter.
- Axle support is the same drop-out design as in motorbikes, having advanced wheel shaft with twin screw securing wheel shaft onto both wheel shaft pinch bolts.
- Wheel shaft (20 mm diam.) available on request.
- Adjustable handlebar support onto upper crown.

Steer tube: EASTON aluminum steer tubes or steel tube available for 1 1/8", threadless.

Crown: Forged and CNC-machined aluminum alloy.

Upper crown: Forged and CNC-machined aluminum alloy. Two versions available for different frame sizes.

Handlebar support: Forged and CNC-machined aluminum alloy. Advanced handlebar axle model also available.

Stanchions: Anodized EASTON aluminum.

Feet: Forged and CNC-machined aluminum alloy.

Springs: worm springs with steady pitch.

Sliders: CNC-machined aluminum alloy.

Slider bushing: composed of a copper base and impregnated with an anti-friction coating.

Seals: Computer designed oil seals and dust seals guarantee the highest quality seals available.

Oil: Specially formulated oil which eliminates foaming and viscosity breakdown while providing complete stiction-free performance.

Fork leg oil: 300 cc, type EBH 16- SAE 7.5.

INSTRUCTIONS

GENERAL RULES

1. *Where specified, assemble and disassemble the suspension system using the **MARZOCCHI** special tools only.*
2. *On reassembling the suspension system, always use new seals.*
3. *Clean all metal parts with a special, preferably biodegradable, solvent such as trichloroethane or trichloroethylene.*
4. *Before reassembling, lubricate all parts in contact with each other using silicone fat spray or specific seal oil.*
5. *Always grease the conic seal rings before reassembling.*
6. *Use wrenches with metric size only. Wrenches with inch size might damage the fastening devices even when their size is similar to that of the wrenches in metric size.*
7. *If two screws are close one to the other, always tighten using a 1-2-1 sequence. In short, screw the first screw just up to the point it is well tightened, then tighten the second screw and then go back to the first one and screw it tighter.*

SHIVER DH Race

FAILURES, CAUSES AND REMEDIES

This paragraph reports some troubles that may occur when using the fork. It also indicates possible causes and suggests a remedy. Always refer to this table before doing any repair work.

FAILURES	CAUSES	REMEDIES
<i>Oil leaking through the dust seal.</i>	<i>1. Oil seal is worn out 2. Stanchion tube is scored 3. Excessive dirt on slider oil seal</i>	<i>1. Replace oil seal 2. Replace oil seal and stanchion tube/ wheel shaft pinch bolt assembly 3. Clean the oil seal seat and replace oil seal and dust seal</i>
<i>Oil leaking through wheel shaft pinch bolt</i>	<i>O-ring seal on the cartridge nut is damaged</i>	<i>Replace the O-ring seal</i>
<i>Fork has not been used for some time and is locked out</i>	<i>Oil seals and dust seals tend to stick to stanchion tube</i>	<i>Raise dust seal and lubricate stanchion tube, oil seal and dust seal</i>
<i>Fork compresses and/or rebounds too fast even though the adjuster is set to hardest damping position</i>	<i>Hydraulic cartridge is faulty</i>	<i>Replace hydraulic cartridge</i>
<i>Adjuster position does not affect fork operation</i>	<i>Dirt inside legs</i>	<i>Clean carefully and change oil</i>
<i>Excessive play of stanchions into the sliders</i>	<i>Main slider bushings are worn</i>	<i>Replace main slider bushings</i>

SHIVER DH Race

RECOMMENDATIONS FOR MAINTENANCE

MARZOCCHI forks are based on advanced technology, supported by year-long experience in the field of professional mountain biking. In order to achieve best results, we recommend to check and clean the area below the dust seal and the stanchion tube after each use and lubricate with silicone oil.

In general, **MARZOCCHI** forks can offer top performance from the start. However, in some cases a short running-in period is required (5-10 hours) for inner adjustments. This running-in period will make fork life longer and ensure fork top performance over time.

IMPORTANT: change oil at least every 100 operating hours.

INSTALLATION

Installing a **SHIVER** on a bicycle is a very delicate operation that should be carried out with extreme care.

- The installation should always be checked by an authorized Service Center.

⚠ WARNING: steering tube must be installed and adjusted in compliance with manufacturer's instructions. Improper installation may jeopardize the safety of the rider.

- The fork is supplied with "**A-Head set**" steering tube to be cut according to frame length.
- The steering tube is pressed into the crown. To replace it, contact an authorized Service Center that will use the required tools.

⚠ WARNING: in case of improper installation of the steering tube into the lower Crown, the rider might lose control of his/her bicycle, thus jeopardizing his/her safety.

FITTING FORK ONTO THE FRAME

- Check the tightening torque of the retaining screws (**29**) before installing the fork to the frame.

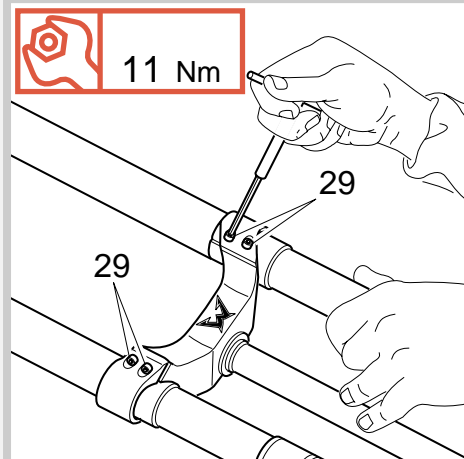

SHIVER DH Race

- Distance “**D**” between lower Crown and tyre edge (when inflated) should not be lower than **193 mm** (total travel + **3 mm**).

⚠ WARNING: if lower Crown is improperly matched with sliders, it may touch the tyre and cause severe injuries to the rider.

- When fitting the slider onto the lower Crown, step **(A)** corresponding to outer diameter variation must be as high as or be higher than the most inner contact point **(B)** between lower Crown **(28)** and sliders.

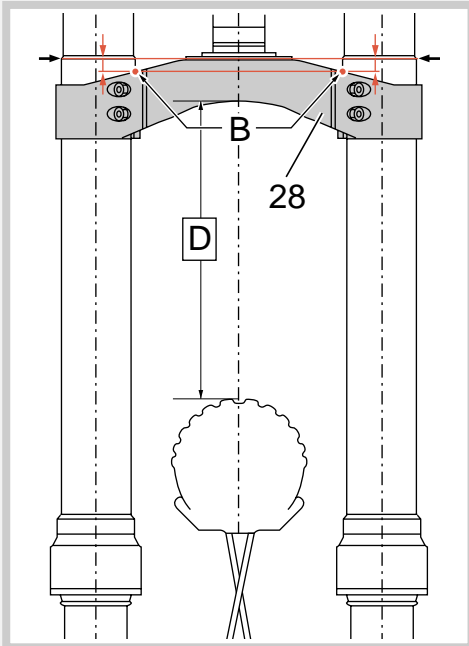

- Assemble the fork to the frame complete with headset.
- Fit the upper crown **(30)** into the upper sliders and the steering tube.
- Ensure that upper surface **(C)** is as high as or higher than the most inner contact point **(D)** between upper crown **(30)** and sliders.
- If fork legs overprotrude, fit some spacers **(E)** to the plate close to the steering tube.

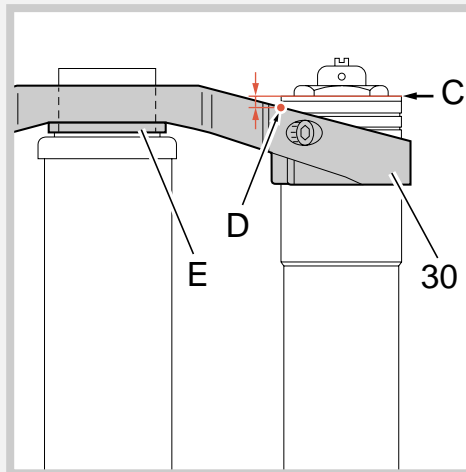

- If the lower Crown position with respect to the sliders has been changed for any reason, adjust the original distance **(D)**.
- Tighten the retaining screws **(29)** holding the sliders to the lower Crown to the specified torque.

⚠ WARNING: do not overtighten the screws **(29)** as this may distort the stanchions and weaken the whole structure.

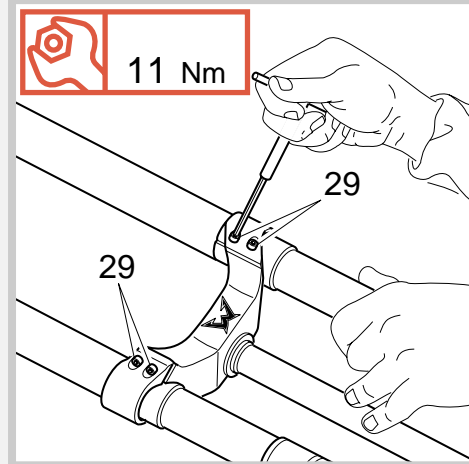

SHIVER DH Race

- Now finally tighten the screws **(29)** on the upper crown to the specified torque.

- Position lower handlebar support **(31)** onto the upper crown **(30)**; holes must be aligned.
- Secure the above two parts together by means of the screws **(29)**. Tighten the screws to the specified torque.
- Fit the handlebar: center in handlebar support and lock by means of upper bolt **(32)** and the screws **(33)**; tighten the screws to the specified torque, working crossways.

DISC BRAKE SYSTEM ASSEMBLY

Assembling the brake caliper onto the wheel shaft pinch bolts is a very delicate operation that should be carried out with extreme care.

Improper assembly might overstress the caliper supports which might break.

This system should be installed by specialized technicians in a position to fully understand and properly follow the instructions given by the manufacturer.

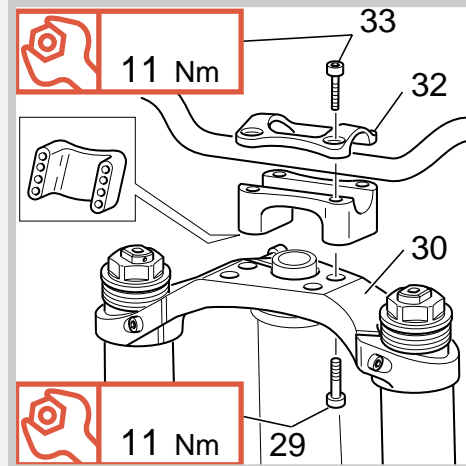
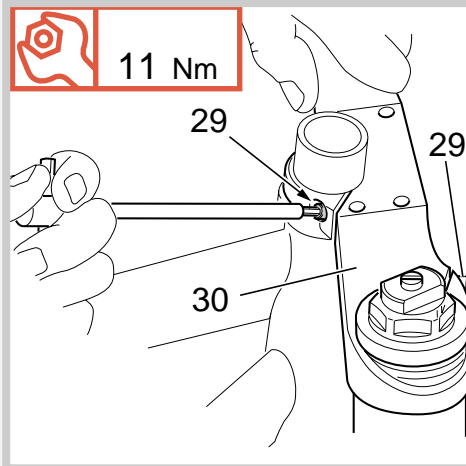

SHIVER DH Race

FITTING WHEEL

- Insert the complete wheel assembly between the legs and fit the wheel shaft (34) into the wheel shaft pinch bolt from the right hand side; push down until it stops against the wheel hub.

- Tighten the wheel shaft screw (35) onto the LH to the specified torque.

- Compress the fork several times so the legs will become properly seated onto wheel shaft. Lock the screws (3) in the wheel shaft pinch bolts to the specified torque.

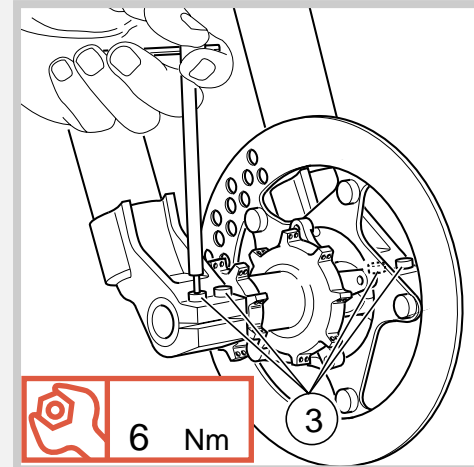
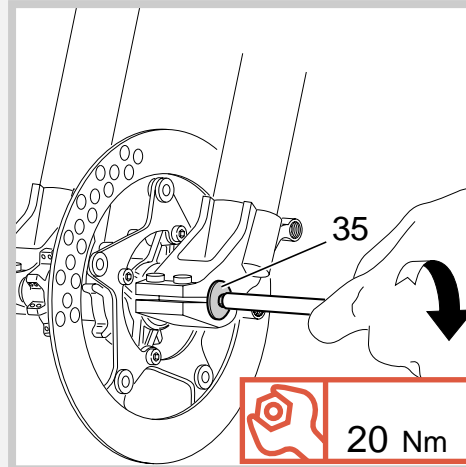
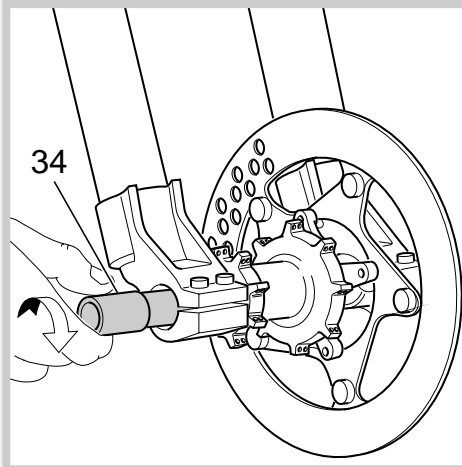

ADJUSTMENTS

SPRING PRELOAD

Turning the adjuster knob **(27)** on top of fork legs to adjust preload of spring for **COMPRESSION** damping. The fork is set to the minimum preload at the factory, i.e. the knob will be completely unscrewed counterclockwise. However, the springs are slightly preloaded to help counteract static loads. By turning the knob clockwise, the preload is increased up to the maximum value equal to **15 mm** of spring preload.

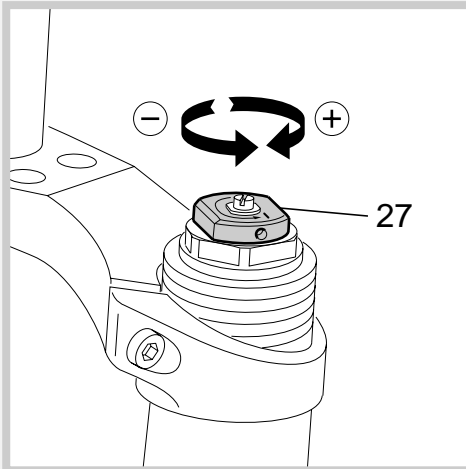

REBOUND

The adjuster screw **(C)** located on top of the leg controls **REBOUND** damping. When turning inside the cartridge rod, this adjuster will change the hydraulic configuration of the inner valves. To adjust, always start from the minimum damping setting, i.e. with the screw fully turned counterclockwise.

IMPORTANT: do not force the adjuster screw **(C)** over its limit.

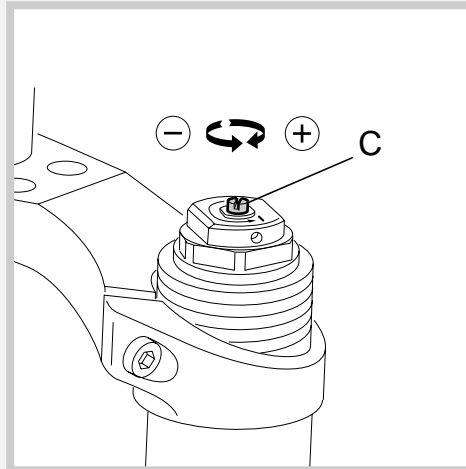

ASSEMBLY INSTRUCTIONS

REMOVING UPPER CAP AND SPRING

NOTE: leave fork legs secured to the lower Crown to remove upper caps from sliders.

Fig. 1

Set the knob (27) to the minimum preload position.

Loosen the grub screw (26) fastening the preload knob by means of a **1.5 mm** Allen wrench. Remove grub screw from cap assembly.

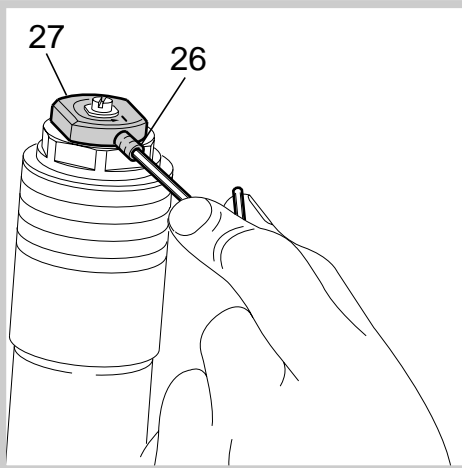

Fig. 2

Remove the stop ring (25) from the top of the preload knob support (8) with a small screwdriver.



WARNING: never use the fork without upper cap otherwise the stanchion might detach from its slider.

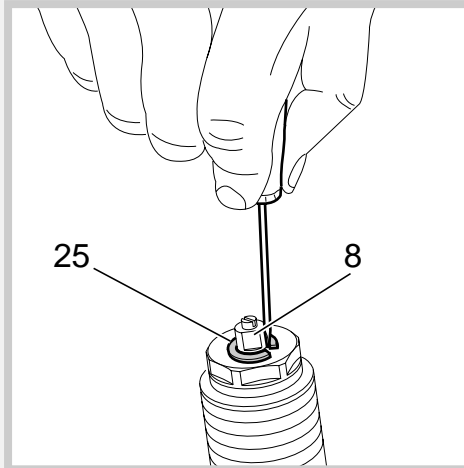
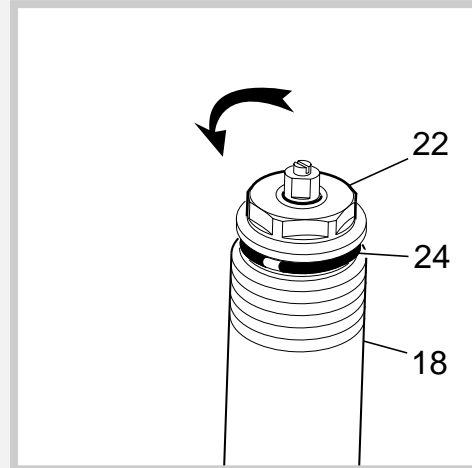

Fig. 3

Remove the cap (22) with a **28-mm** socket wrench.

Remove the cap complete with O-ring (24) from the slider (18).

Now the legs can be removed from the lower Crown.



SHIVER DH Race

Fig. 4

Push down the outer slider onto the stanchion tube.
Lock the check nut (7) and remove the cap (22) from hydraulic cartridge top (8).

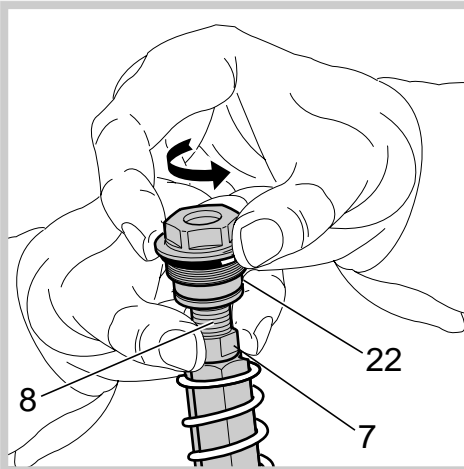
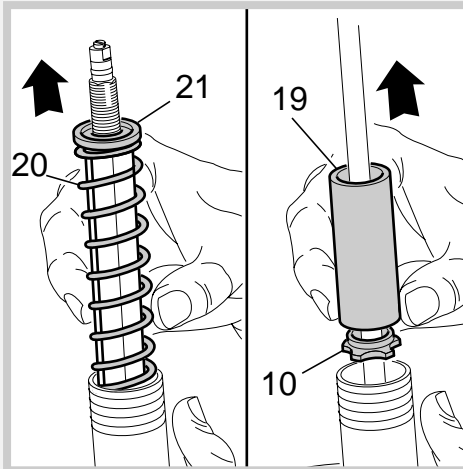



Fig. 5

Push the stanchion tube into the slider and remove the upper washer (21), the spring (20), the preload sleeve (19) and the bearing washer (10).
Remove all parts and let all the oil drain into the fork leg. By following this procedure, there is no need to check the oil level.
Make all necessary changes.



REMOVING HYDRAULIC CARTRIDGE

Fig. 6

 Let all the oil drain out.

WARNING: dispose of exhausted oil in compliance with current laws.

To change the fork leg oil follow the procedure as described at section FILLING WITH OIL.

Remove the stanchion tube from the slider.
Turn the stanchion tube upside-down and unscrew the foot nut (1) complete with O-ring (2) using a 15 mm socket wrench.

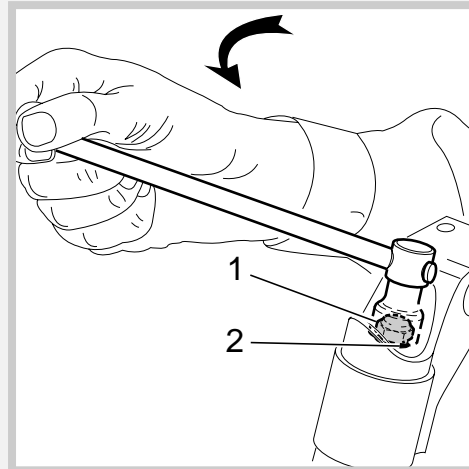

SHIVER DH Race

Fig. 7

Pull the hydraulic cartridge (6) from stanchion tube top and make all necessary changes.

NOTE: when supplied the hydraulic cartridge is complete with seals (see exploded view), spring guide (15), check nut (7) and preload knob support (8). These parts are available also separately.

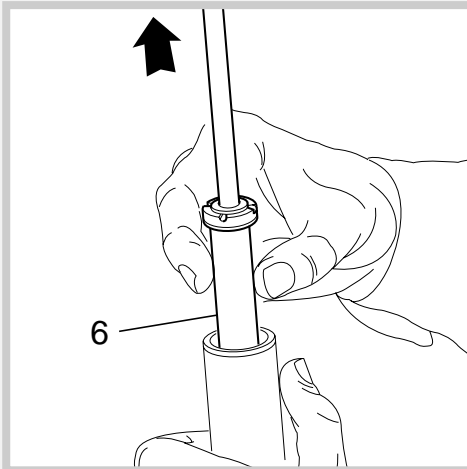

REMOVING GUIDE BUSHING AND SEAL ASSEMBLY

Fig. 8

Turn the slider upside-down and remove the dust seal (11).

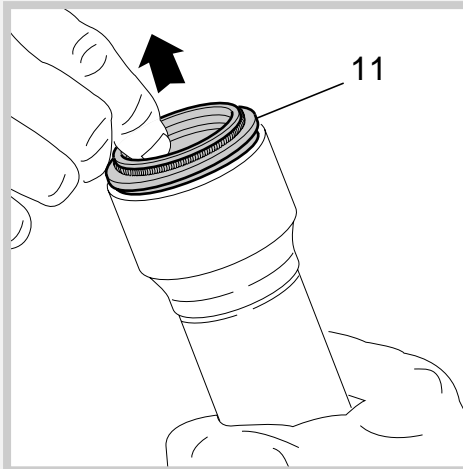
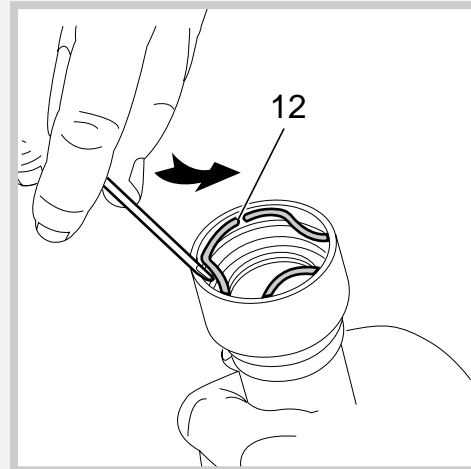

Fig. 9

Remove the stop ring (12) from the slider by placing the screwdriver bit in one of the three openings on the stop ring and carefully lifting the ring out of place.

IMPORTANT: when removing the stop ring, make sure not to damage slider inner seat.



SHIVER DH Race

Fig. 10

Fit the slider protector **(A)** onto the slider and remove the oil seal **(13)** with the help of a large slot screwdriver.

IMPORTANT: when removing the oil seal, make sure not to damage slider inner seat. Once removed the oil seals should not be used again.

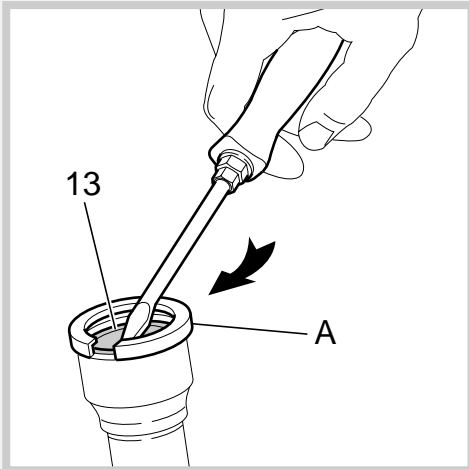

Fig. 11

Remove bush washer **(14)** from the slider.

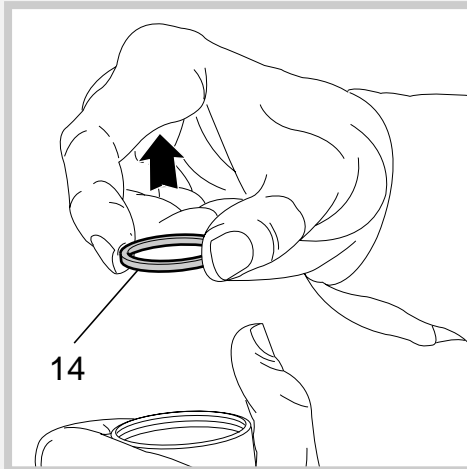
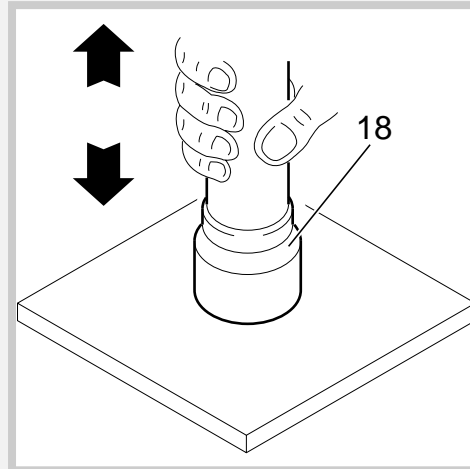

Fig. 12

To remove the guide bushing **(16)** and the spacer **(17)**, beat powerfully the slider edge **(18)** on a wooden surface. Perform this operation with extreme care and try to keep the slider perpendicular to the wooden surface. Use a bush puller in case of need and do not scratch slider inner surface. Make all necessary changes.



SHIVER DH Race

ASSEMBLING GUIDE BUSHING AND SEAL ASSY

Fig. 13

Check that no dirt or debris is between slider and bushing and grease with fork oil all parts.

Fit the upper bushing (16) and use the spacer (17) to push it into the slider.

Fit the other guide bushing (16). In case of need, use the drift (B) to seat it into the slider.

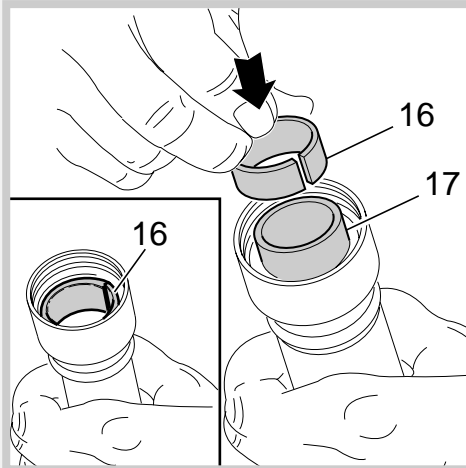

Fig. 14

Fit the bush washer (14) into the slider so that it touches the guide bushing.

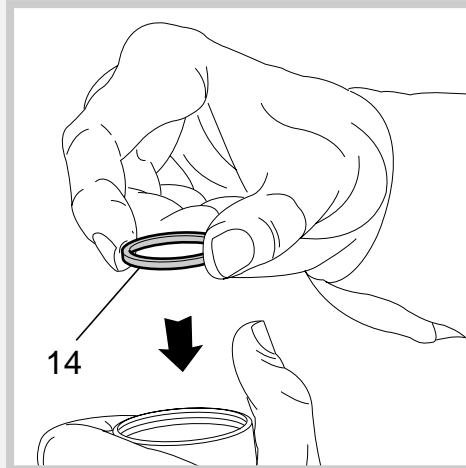
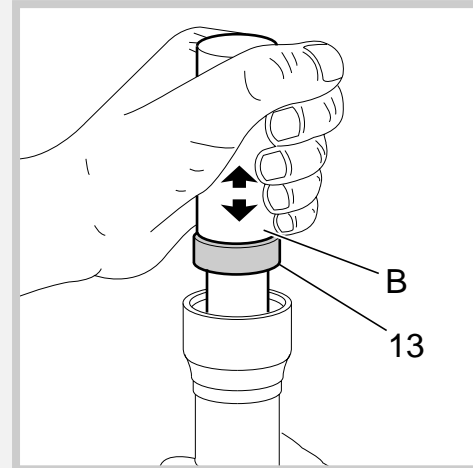

Fig. 15

Lubricate the oil seal (13) and place it onto the drift (B) with the hollow side toward the slider.

Press the oil seal into place until it touches the bush washer by using the above drift.



**SHIVER
DH
Race**

Fig. 16

Insert the stop ring (12) and make sure it is properly seated into place in the slider. Use the drift (B) used previously to properly seat the seal.

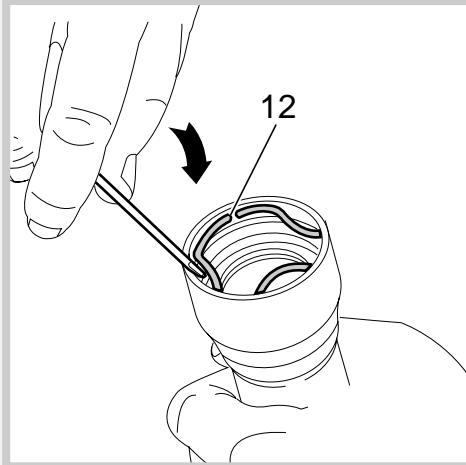

Fig. 17

Lubricate the dust seal (11) and insert it into the stanchions from the spring end.

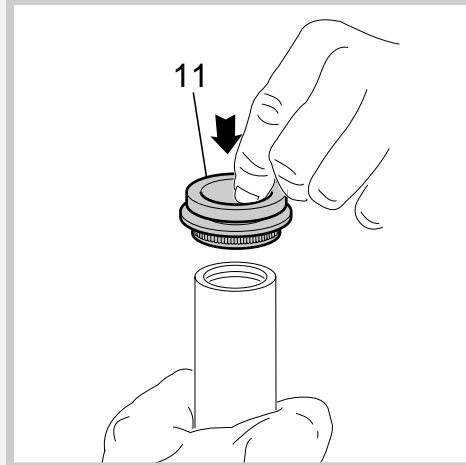
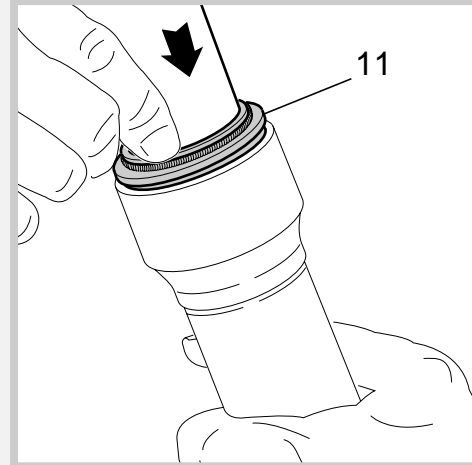

Fig. 18

Duly lubricate the stanchion tube and fit it into the slider fully down. Insert the dust seal (11) into the slider.



SHIVER DH Race

RE- ASSEMBLING HYDRAULIC CARTRIDGE

Fig. 19

Insert the hydraulic cartridge (6) complete with seals and caps with the stanchion pressed fully down into the slider.

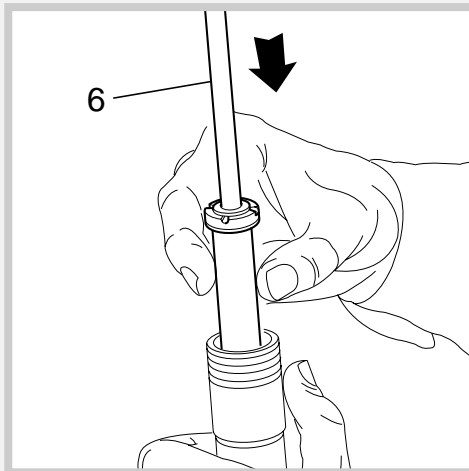
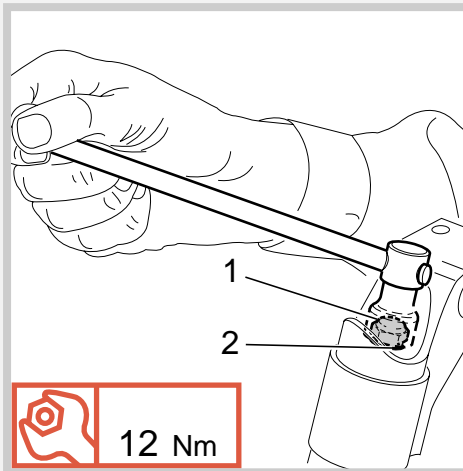

Fig. 20

Grease the O-ring (2) on the foot nut (1) and screw the nut on the hydraulic cartridge threaded end.

Tighten to specified torque.

Pump stanchion up and down several times to make sure it slides properly through the stroke.



HOW TO FILL WITH OIL

Fig. 21

Pour the oil little by little when the slider is fully down on the stanchion tube and then pump with the cartridge (6) rod so as to have a better filling.

Cartridge is full when no air is detected when pumping, in the fully compressed position (clockwise).

Check that the oil level is **80 mm** from the top of the slider in each leg.

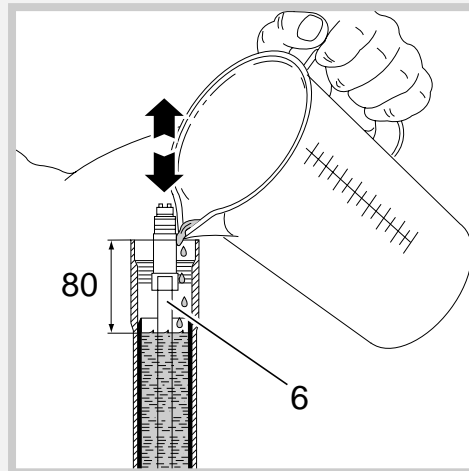

SHIVER DH Race

RE-ASSEMBLING SPRING AND UPPER CAP

Fig. 22

Fit bearing washer (10), preload sleeve (19), spring (20) and upper washer (21) in each fork leg.

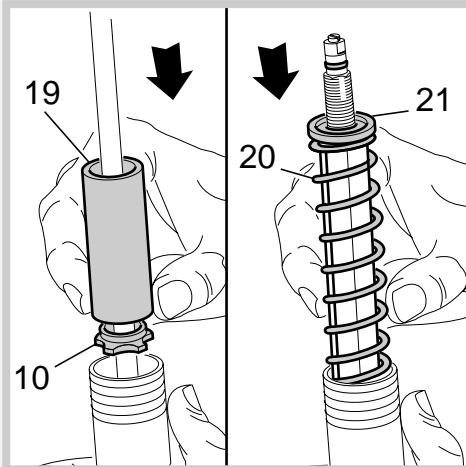

Fig. 23

Move the plunger (23, see exploded view), in the cap (22), to the minimum preload position.

Screw the cap (22) on preload knob support top (8) until it rests against the check nut (7).

Lock the check nut (7) on cap (22) with the wrenches used for disassembling.

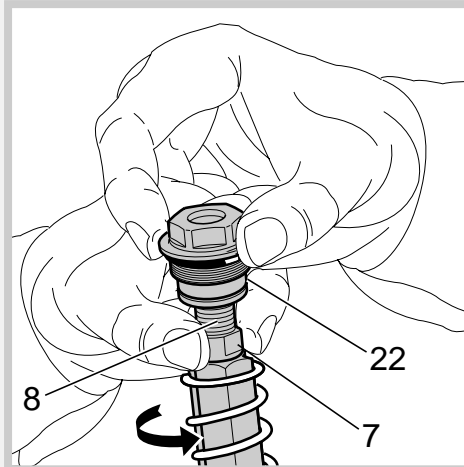
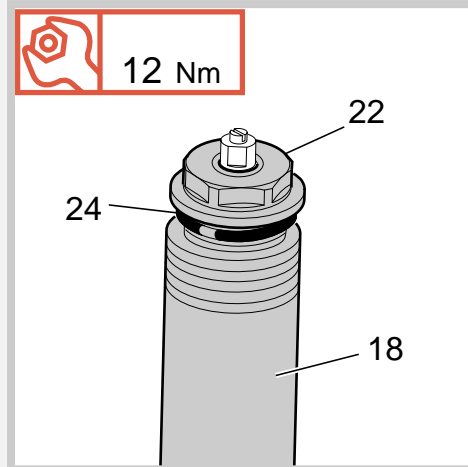

Fig. 24

Lubricate the O-ring (24), lift slider (18) and fit the cap (22) by hand.

Tighten the cap to the specified torque.



SHIVER DH Race

Fig. 25

Fit the stop ring (25) of the preload knob support (8) and make sure it is properly



seated into place.

WARNING: never use the fork without this part otherwise the stanchion might detach from its slider and cause serious accidents.

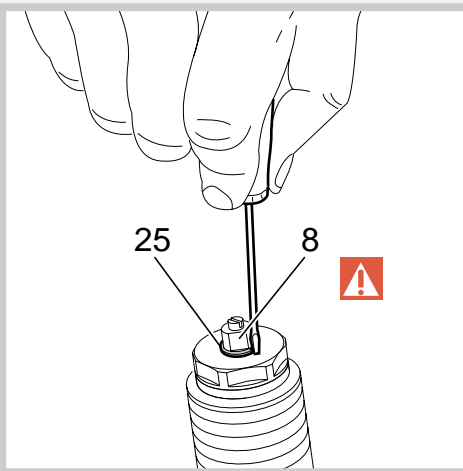
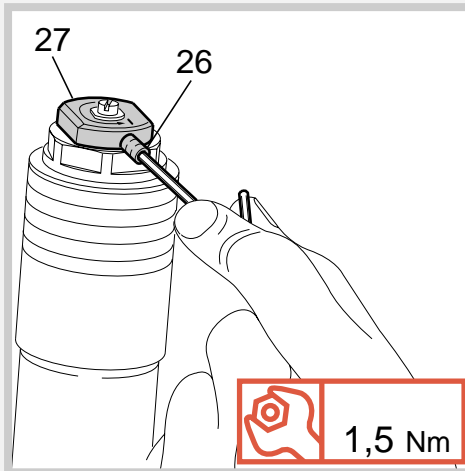

Fig. 26

Fit the preload knob (27) and secure it on the support (8) by tightening the grub screw (26) to specified torque.

Now fit the fork legs onto the lower Crown as described in "INSTALLATION" section.



SPECIFIC MARZOCCHI TOOLS

Ref.	Item	Description and use
A	R 5099 AC	Slider protector: to remove the oil seal from the slider
B	R 5098 AC	Oil seal press: to press oil seal into the slider

