

Z1
Wedge
ext.
Preload
(110)

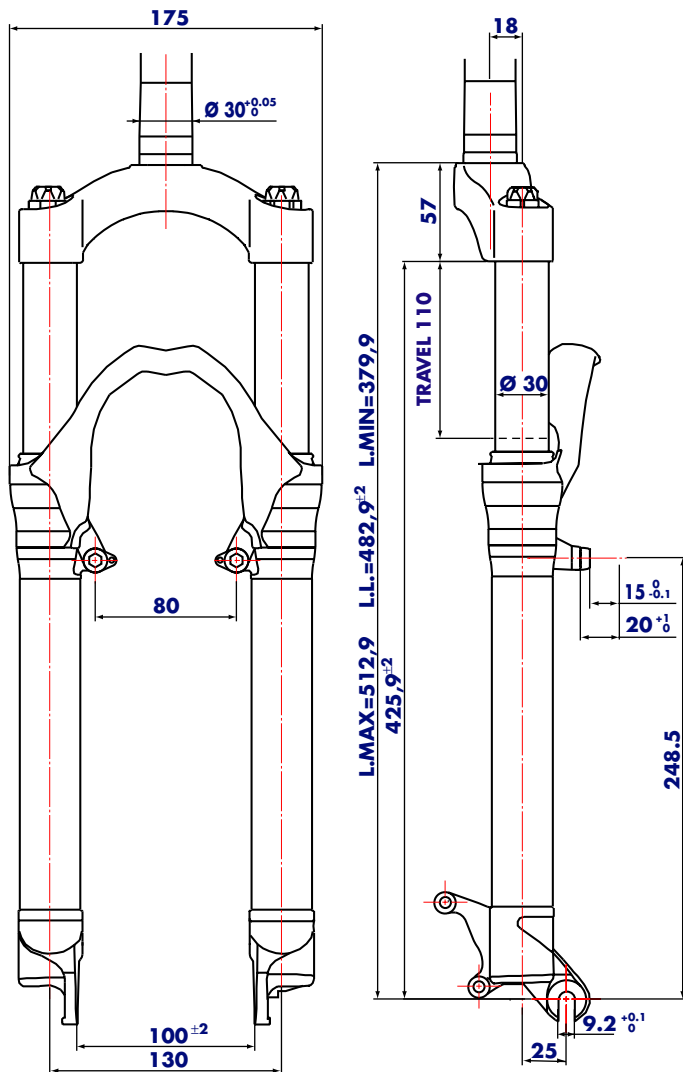

GENERAL

- The fork is sprung by a mechanical coil system and uses hydraulic rebound damping for Freeride use.
- Rebound damping is controlled by pumping rods fixed to the bottom of each slider; it can also be adjusted from the inside of the stanchions.
- Spring pre-load adjustment controlled via external adjuster on stanchion plugs.
- Stanchions fitted into lower Crown by cryofit technique. Full length bushings guarantee superior rigidity.
- Sliders and arch are an integral assembly for reduced weight and improved rigidity.
- Parts subjected to friction are cooled and lubricated by a specially formulated oil.

Steer tube: stainless steel available for 1 1/8" diameter, threadless.

Crown: Forged and CNC-machined BAM* aluminum alloy.

Arch: Cast aluminum alloy.

Stanchions: anodized aluminum with variable section.

Springs: Constant pitch springs.

Sliders: forged and CNC-machined aluminum. Left slider comes with supports for disc brake caliper.

Slider bushing: Full length guide bushings composed of a copper base and impregnated with an anti-friction coating.

Seals: Computer designed oil seals guarantee the highest quality seals available.

Oil: Specially formulated oil which eliminates foaming and viscosity breakdown while providing complete stiction-free performance.

Fork leg oil: 85 cc (each leg), type EBH 16 - SAE 7.5.

* **BAM: Bomber Aerospace Material.**
Special alloy developed from aerospace material.

Z1
Wedge
ext.
Preload
(130)

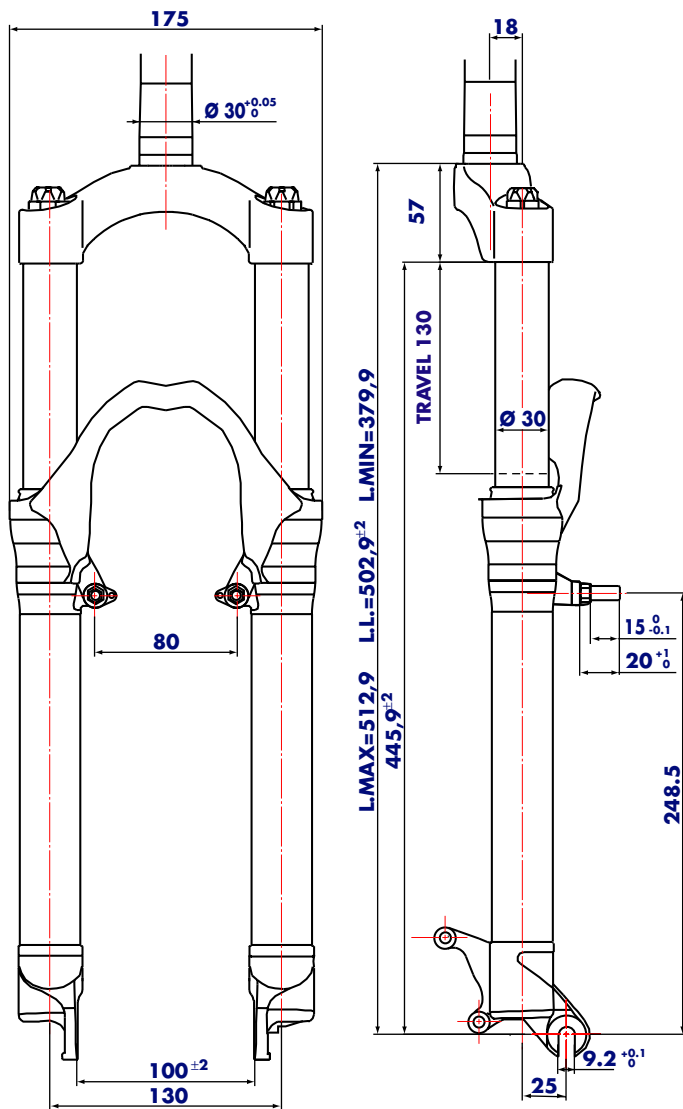

GENERAL

- The fork is sprung by a mechanical coil system and uses hydraulic rebound damping for Freeride use.
- Rebound damping is controlled by pumping rods fixed to the bottom of each slider; it can also be adjusted from the inside of the stanchions.
- Spring pre-load adjustment controlled via external adjuster on stanchion plugs.
- Stanchions fitted into lower Crown by cryofit technique. Full length bushings guarantee superior rigidity.
- Sliders and arch are an integral assembly for reduced weight and improved rigidity.
- Parts subjected to friction are cooled and lubricated by a specially formulated oil.

Steer tube: stainless steel available for 1 1/8" diameter, threadless.

Crown: Forged and CNC-machined BAM* aluminum alloy.

Arch: Cast aluminum alloy.

Stanchions: anodized aluminum with variable section.

Springs: Constant pitch springs.

Sliders: forged and CNC-machined aluminum. Left slider comes with supports for disc brake caliper.

Slider bushing: Full length guide bushings composed of a copper base and impregnated with an anti-friction coating.

Seals: Computer designed oil seals guarantee the highest quality seals available.

Oil: Specially formulated oil which eliminates foaming and viscosity breakdown while providing complete stiction-free performance.

Fork leg oil: 90 cc (each leg), type EBH 16 - SAE 7.5.

* **BAM: Bomber Aerospace Material.**

Special alloy developed from aerospace material.

INSTRUCTIONS

GENERAL RULES

1. Where specified, assemble and disassemble the shock absorption system using the **MARZOCCHI** special tools only.
2. On reassembling the suspension system, always use new seals.
3. Clean all metal parts with a special, preferably biodegradable solvent, such as trichloroethane or trichloroethylene.
4. Before reassembling, lubricate all parts in contact with each other using silicone fat spray or a specific oil for seals.
5. Always grease the lip seal rings before reassembling.
6. Use wrenches with metric size only. Wrenches with inch size might damage the fastening devices even when their size is similar to that of the wrenches in metric size.

Z1
Wedge
ext.
Preload

FAILURES, CAUSES AND REMEDIES

This paragraph reports some failures that may occur when using the fork. It also indicates possible causes and suggests a remedy. Always refer to this table before doing any repair work.

FAILURES	CAUSES	REMEDIES
<i>Oil leaking though the top of slider</i>	<i>1. Oil seal is worn out 2. Stanchion tube is scored 3. Excessive dirt on oil seal</i>	<i>1. Replace oil seal 2. Replace crown/stanchions assembly, oil seals and dust seals 3. Clean the oil seal seat and replace oil seal</i>
<i>Oil leaking through the bottom of slider</i>	<i>O-ring on pumping rod nut damaged</i>	<i>Replace the O-ring</i>
<i>Fork has not been used for some time and is locked out</i>	<i>Oil seals and dust seals tend to stick to stanchions</i>	<i>Raise dust seal and lubricate stanchion tube, dust seal and oil seal</i>
<i>Excessive play of stanchions in the sliders</i>	<i>Pilot bushings are worn</i>	<i>Replace pilot bushings</i>
<i>Fork rebounds too fast in any adjuster position</i>	<i>Dirt inside fork legs</i>	<i>Clean carefully and change oil</i>
<i>Adjuster position does not affect fork operation</i>	<i>1. Dirt inside legs 2. Pumping element does not work properly</i>	<i>1. Clean carefully and change oil 2. Replace pumping element</i>

Z1
Wedge
ext.
Preload

Z1 Wedge ext. Preload

RECOMMENDATIONS FOR MAINTENANCE

MARZOCCHI forks are based on advanced technology, supported by year-long experience in the field of professional mountain biking. In order to achieve best results, we recommend to check and clean the area below the dust seal and the stanchion tube after each use and lubricate with silicone oil.

In general, **MARZOCCHI** forks can offer top performance from the start. However, in some cases a short running-in period is required (5-10 hours) for inner adjustments. This running-in period will make fork life longer and ensure fork top performance over time.

IMPORTANT: change oil at least every 100 working hours.

Polished forks should be cleaned with bodywork **polish** at regular intervals in order to preserve their original finish.

INSTALLATION

Installing the fork on a bicycle is a very delicate operation that should be carried out with extreme care. The installation should always be checked by one of our Technical Service Centers.



WARNING: Steer tube/headset mounting and adjustment must be carried out in compliance with the headset manufacturer's instructions. Improper installation may jeopardize the safety of the rider.

To replace it, contact one of our Technical Service Centers with the required tools.



WARNING: In case of improper installation of the steer tube into the crown, the rider might lose control of his/her bicycle, thus jeopardizing his/her safety.

DISC BRAKE SYSTEM ASSEMBLY



WARNING: If a disc brake system is installed, it is absolutely forbidden to loosen and remove original brake supports fixing pins. In fact, apart from retaining Cantilever or V-brake levers, they also play an important role in securing slider bottom to slider-arch monolith. If needed, replace these pins with screws (part no. **532979QF**) available as spare parts. Tighten the above screws to 10 Nm.

IMPORTANT: screw and pin threading is treated to ensure hydraulic seal. Never reuse screws and pins which have been removed.

Assembling the brake caliper onto the slider is a very delicate operation that should be carried out with extreme care. Improper assembly might overstress the caliper supports which might break. When installing the disc brake system, be sure to properly follow the instructions given by the manufacturer.

ADJUSTMENT

SPRING PRELOAD

Spring preload determines COMPRESSION damping and is adjusted by turning the adjustment knob **(3)** on the top of the fork legs. From the factory the fork is set at minimum preload, i.e. the adjustment knob completely unscrewed counterclockwise. However, springs are slightly preloaded to counteract static loads. By turning the adjustment knob clockwise, the preload is increased up to the maximum value equal to 15 mm spring preload. This adjustment is essential in order to have the right fork response for the rider's weight and riding style.

Z1
Wedge
ext.
Preload

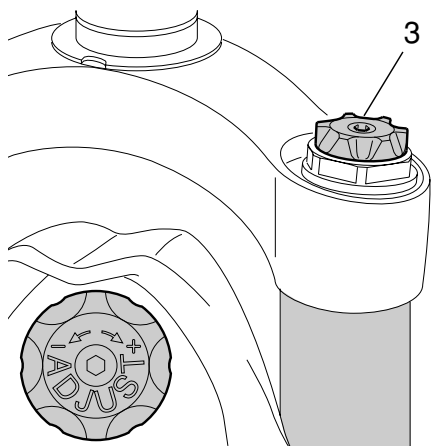

REBOUND ADJUSTMENT VIA INNER PUMPING ROD

The adjuster controlling REBOUND damping adjustment is accommodated inside pumping rod **(10)** inside each fork leg.

To access the adjuster, unscrew the top cap **(4)** and push the stanchions fully down (see section DISASSEMBLY **Fig. 1**).

Fit the supplied hexagon rod **(C)** into the stanchion tube and into the adjuster inner hole. Rotate the adjuster clockwise for harder damping, counterclockwise to soften it.

Refit the cap **(4)** and tighten it to the specified torque (see section REASSEMBLY, **Fig. 24**).

IMPORTANT: Do not remove the springs or this will alter the amount of oil inside the fork legs.

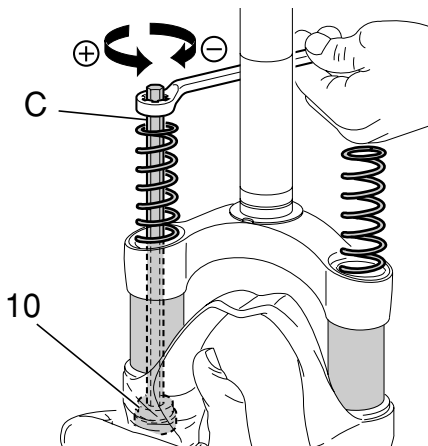

DISASSEMBLY

GENERAL

- The reference numbers given in this section relate to the components shown in the fork exploded view.
- Before starting any operation. please read the diagram below. It shows the quickest procedure and the exact disassembling sequence. Locate the part you need to remove in the diagram, then look at the arrows to determine which other parts you need to remove first.

DISASSEMBLY DIAGRAM

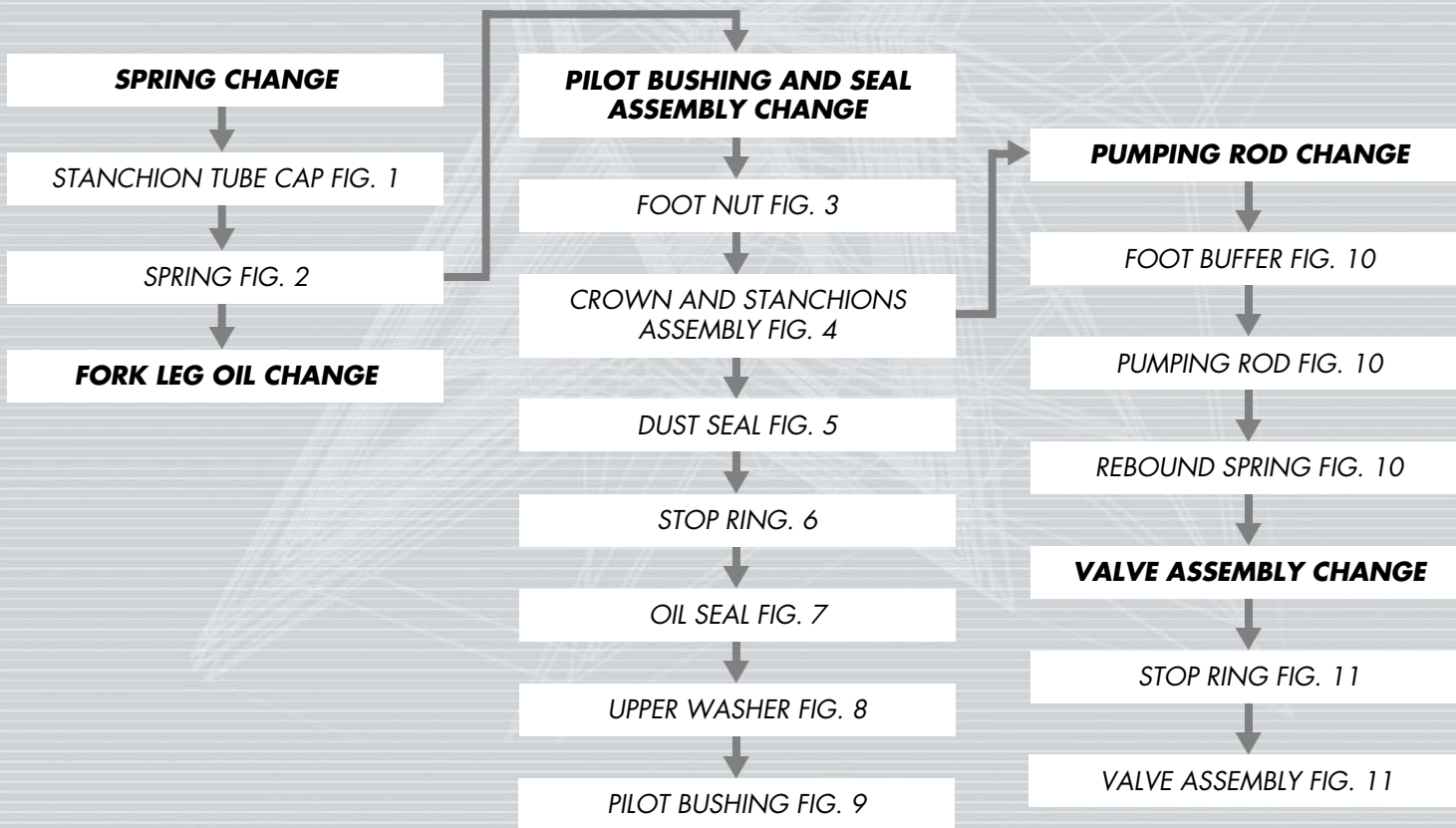

Z1
Wedge
ext.
Preload

SPRING CHANGE

FIG. 1

Unscrew the caps (4) with a 21 mm socket wrench.

Remove the caps complete with O-ring (5) from the stanchions.

FIG. 2

Push the stanchions into the sliders and remove the lower washer (33) and the spring (8) from each fork leg.

Drain all oil from the fork legs.



WARNING: Remember to always recycle any used oil.

To change the fork leg oil follow the procedure as described in section "REASSEMBLY" from Fig. 22 to Fig. 24.

PILOT BUSHING AND SEAL ASSEMBLY CHANGE

FIG. 3

Turn the fork leg upside-down and unscrew the foot nuts (22) by the use of a 15 mm socket wrench.

Z1
Wedge
ext.
Preload

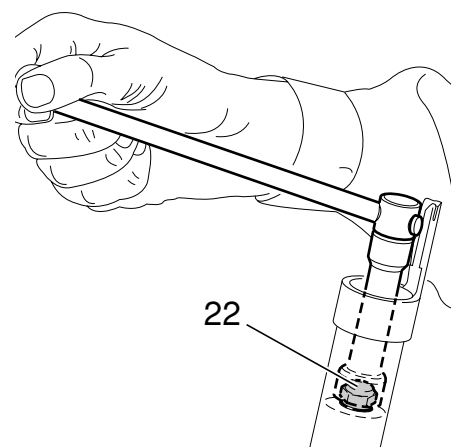
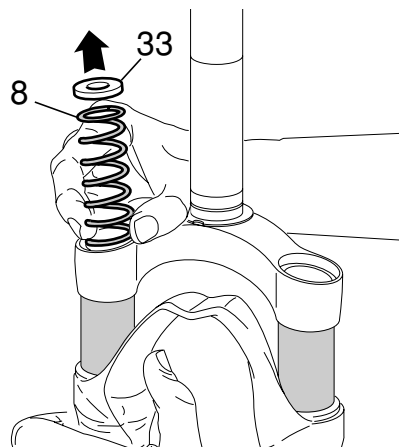
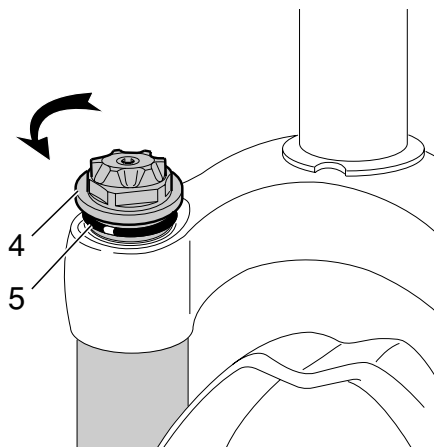

Z1
Wedge
ext.
Preload

FIG. 4

Withdraw the crown and stanchions assembly (1) from the sliders (20).

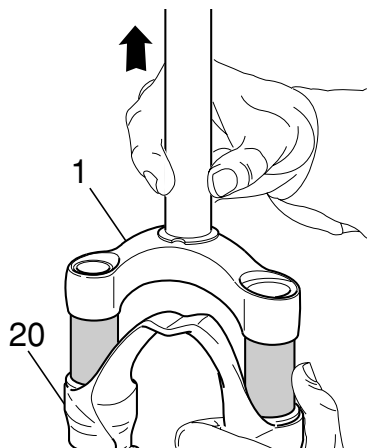

FIG. 5

Remove the dust seal (15) from the top of the sliders using a small screwdriver.

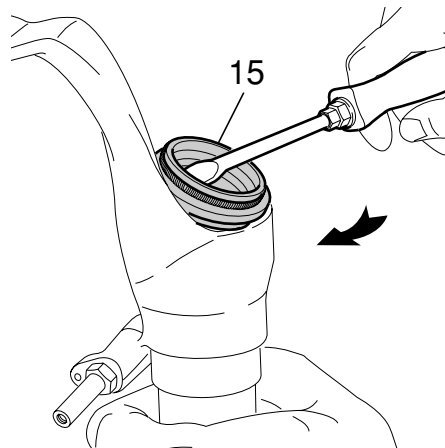
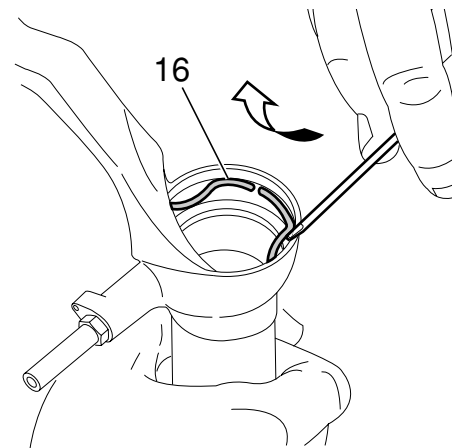

FIG. 6

Remove the stop ring (16) from the sliders by placing the screwdriver bit in one of the three openings on the stop ring.

IMPORTANT: when removing the stop ring, make sure not to damage its seat.



Z1
Wedge
ext.
Preload

FIG. 7

Fit the slider protector **(A)** onto the slider and remove the oil seal **(17)** with the help of a large screwdriver.

IMPORTANT: when removing the oil seal, make sure not to damage its seat. Once removed the oil seals should not be used again.

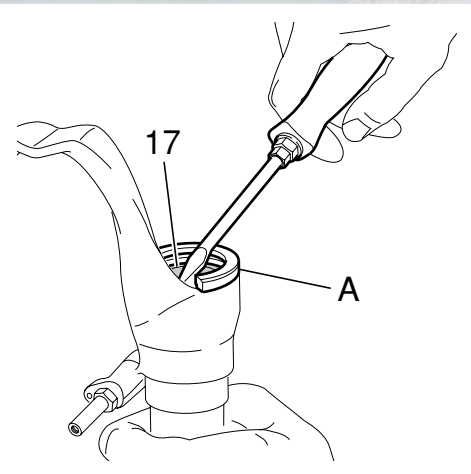

FIG. 8

Remove the upper washer **(18)** from the slider.

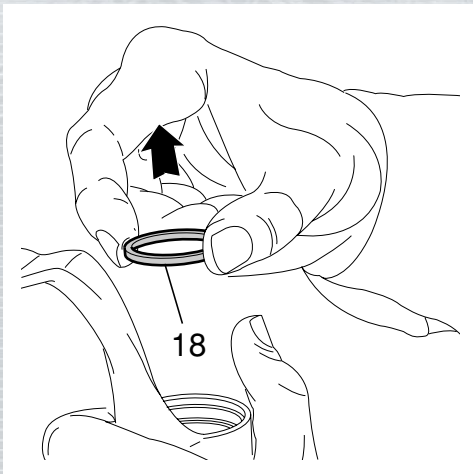
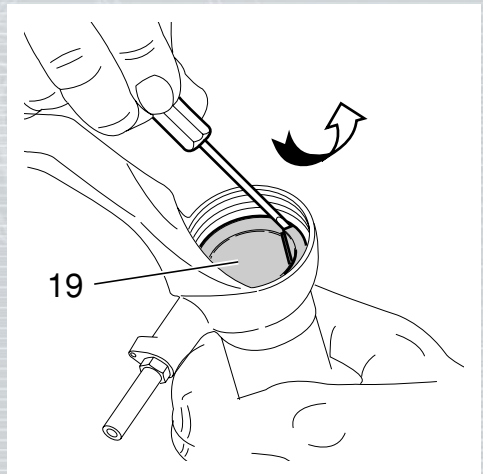

FIG. 9

Fit the bit of a small screwdriver into upper edge slot of the pilot bushing **(19)** and lift gently. Pull the bushing out of the slider and make all necessary changes.



PUMPING ROD CHANGE

FIG. 10

Remove the foot buffer (14) with the o-ring (27) from the pumping rod (10) end. Withdraw the complete pumping rod (10) and the rebound spring (11) from the top. Replace the seal ring (9) if damaged or worn out.

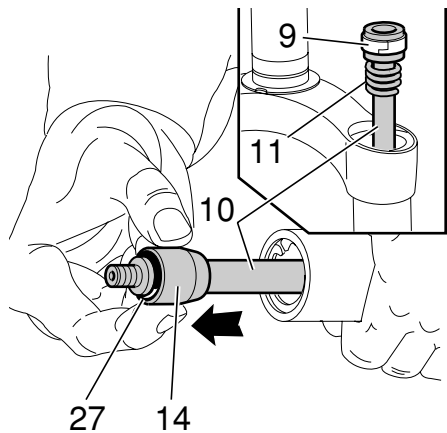

VALVE ASSEMBLY CHANGE

FIG. 11

To check that the valve assembly is operating correctly, it is necessary to work on the inside of the stanchion tube. Slip off the stop ring (13) using pointed pliers. Pull the valve assembly out of the stanchion with one finger in the following order: pocket (30), valve (29) and washer (12).

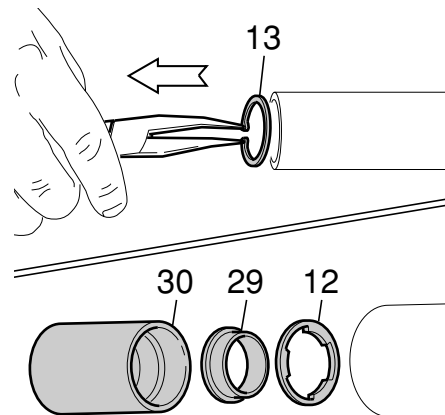

Z1
Wedge
ext.
Preload

Z1
Wedge
ext.
Preload

REASSEMBLY

CAUTION: before reassembling, all metal components should be washed carefully with inflammable, preferably biodegradable, solvent and dried with compressed air.

PILOT BUSHING AND SEAL ASSEMBLY

FIG. 12

Check that no dirt or debris is between slider and bushing. Insert the pilot bushing (19) into place so that it adheres to the slider.

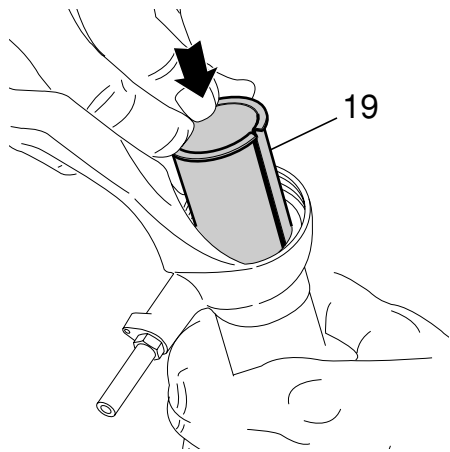

FIG. 13

Fit the upper washer (18) into the slider so that it touches the pilot bushing.

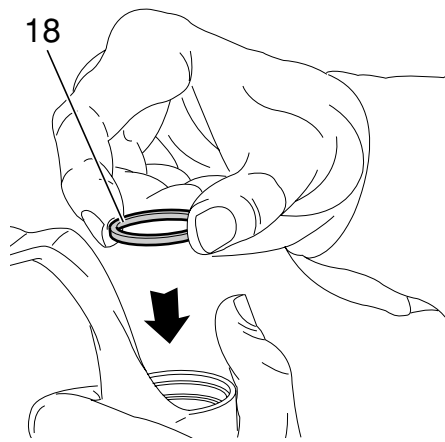
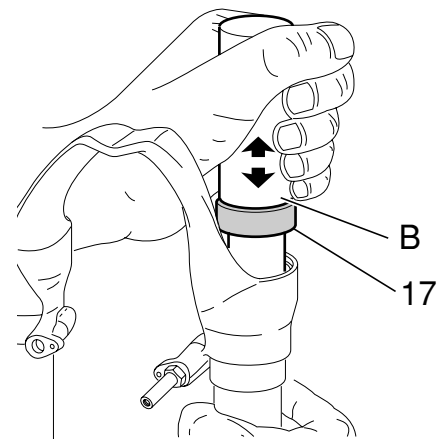

FIG. 14

Lubricate the oil seal (17) and place it onto the seal press (B) with the hollow side toward the slider.

Press the oil seal until it touches the lower washer by using the above seal press.



Z1
Wedge
ext.
Preload

FIG. 15

Insert the stop ring (16) into the slider making sure it is properly seated into place. Use buffer (B) to properly seat the ring into the slider.

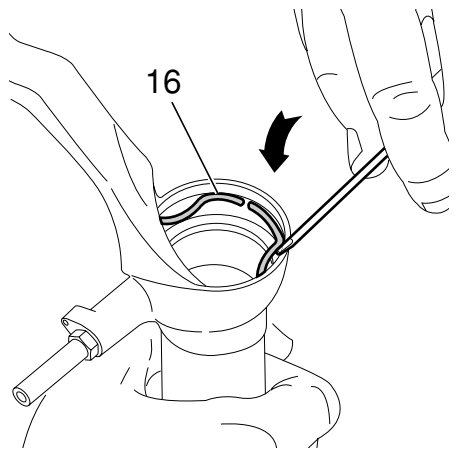
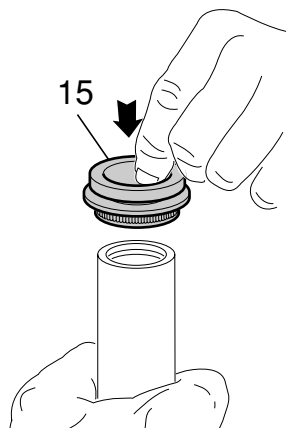

FIG. 16

Lubricate the dust seals (15) and fit them into the stanchions from the spring end.



VALVE AND PUMPING ROD ASSEMBLY

FIG. 17

After having overhauled or replaced the valve unit and after having cleaned the inside of the tube, reassemble. Assemble valve components, in correct sequence: washer (12), valve (29) and pocket (30). Then fit pumping rod (10) with seal ring (9) and rebound spring (11) into the valve assembly.

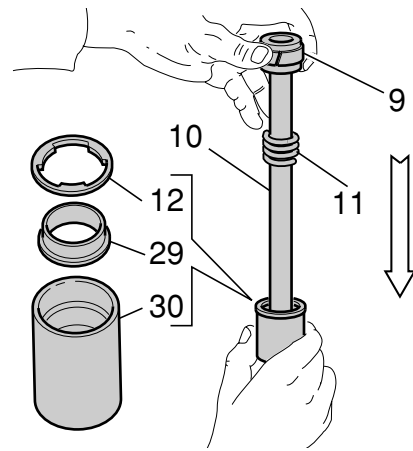

Z1
Wedge
ext.
Preload

FIG. 18

Lubricate O-rings (27) and (26) and reassemble the foot buffer (14) onto the end part of pumping rod (10).

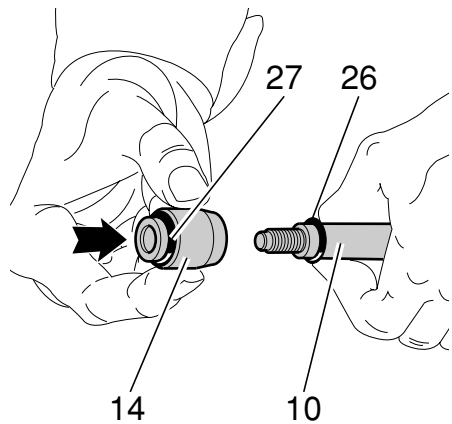
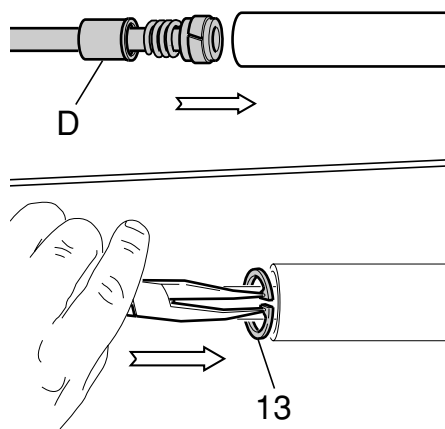

FIG. 19

Fit this assembly into the stanchion tube and properly seat the valve assembly (D). Insert the stop ring (13).



CROWN AND STANCHIONS ASSEMBLY

FIG. 20

Fit the crown and stanchions assembly (1) - with the dust seals in place - gently into the sliders seals.

WARNING: to avoid any damages to sealing surfaces, keep the stanchions duly lubricated and squared into the sliders.

Press the crown and stanchions assembly fully down and check that threaded ends of pumping elements (10) are coming out through the bottom of the sliders.

Check to see that the stanchions slide unrestricted by cycling the fork up and down several times.

The tube should slide freely inside the seal assembly without any side play. In the event it is too hard or too soft, repeat the previous steps described above and check components to ensure they are not damaged.

Seat the dust seals (15) on top of the sliders.

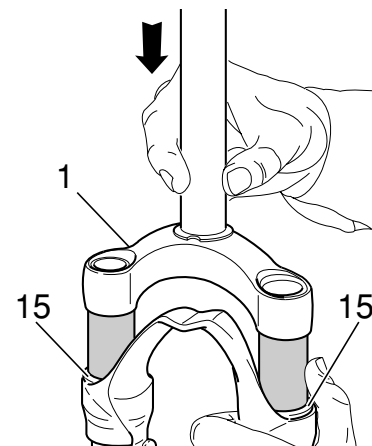

Z1
Wedge
ext.
Preload

FIG. 21

Screw the foot nut (22) onto the pumping rod threaded end (10).
Tighten to 11 Nm.
Check to verify that the stanchions slide properly through the stroke by pumping them up and down several times.

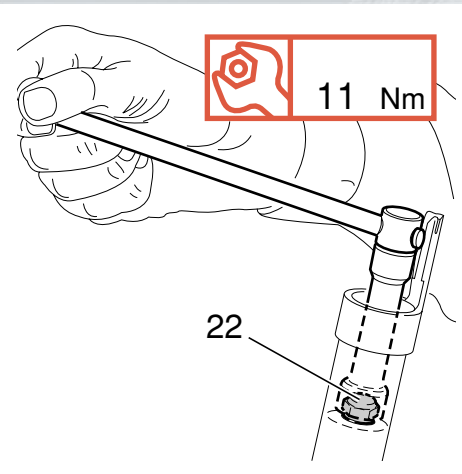

HOW TO FILL WITH OIL

FIG. 22

Pour oil little by little when the stanchions are fully down and then pump with the crown so as to have a better filling.
Check that the oil level (H) is as required in both legs.

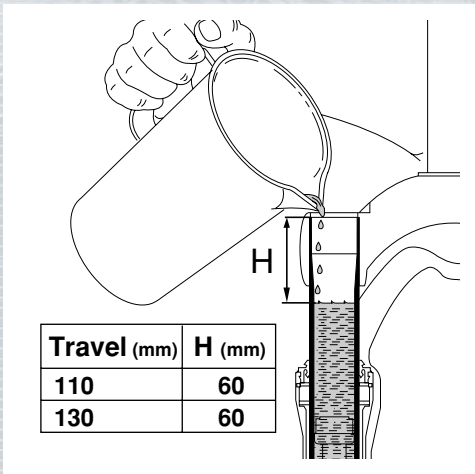

SPRING AND CAP

FIG. 23

Fit the spring (8) and lower washer (33) into each stanchion tube.

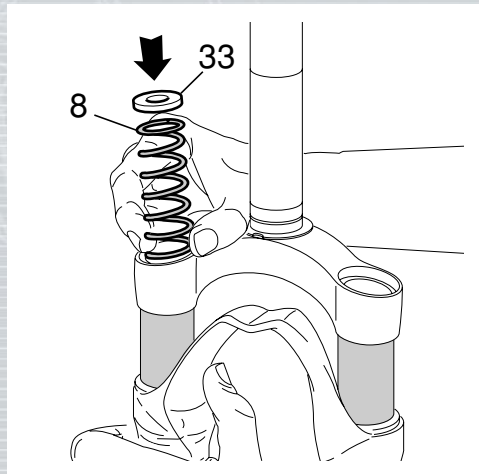

Z1
Wedge
ext.
Preload

FIG. 24

Lubricate the O-ring **(5)** on the cap **(4)**. Turn the preload adjuster **(31)** counter-clockwise until it is at its minimum setting (see section ADJUSTMENT).

Start the complete cap assembly into the stanchion tube thread by hand. Tighten the cap **(4)** to 20 Nm.

Set spring preload as specified in section ADJUSTMENT.

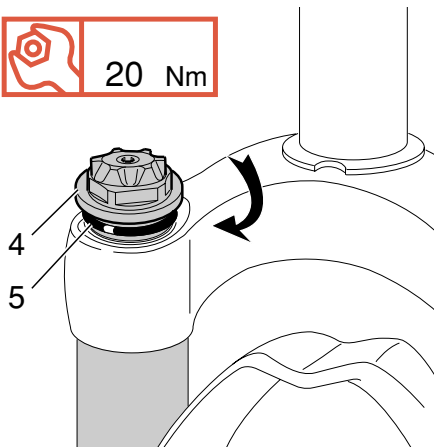

SPECIFIC TOOLS

Ref.	Item.	Description and use
A	R 5089 AB	Slider protector: to remove the oil seal from the slider
B	R 5090	Oil seal press: to press oil seal into the slider
C	R 5085	Hexagon wrench: to set rebound adjuster

Z1
Wedge
ext.
Preload

