

Instruction  
Manual



**BAM**  
BOMBER  
AEROSPACE  
MATERIAL



**ALLOY**



**bomber**

MARZOCCHI SINCE 1949 MARZOCCHI SINCE 1949 MARZOCCHI SINCE 1949



**INDEX**

	Page
OWNER'S INFORMATION .....	2
GENERAL .....	3
SPECIFIC MARZOCCHI TOOLS .....	3
GENERAL RULES FOR A CORRECT OVERHAULING AND MAINTENANCE .....	4
FAILURES, CAUSES AND REMEDIES .....	4
RECOMMENDATIONS FOR MAINTENANCE .....	4
INSTALLATION .....	4
SPRING PRELOAD ADJUSTMENT .....	5
DISASSEMBLY .....	5
DISASSEMBLY DIAGRAM .....	6
REASSEMBLY .....	9
FORK EXPLODED VIEW .....	13

The figures and descriptions in this pamphlet are provided as a guide.  
 We reserve the right to make changes to the products without notice in line with our policy of continuous improvement.

**Always respect Nature when riding !**

**OWNER'S INFORMATION**

**IMPORTANT:** Installing a Marzocchi suspension system is a very delicate operation that must be carried out with extreme care. These installation and maintenance instructions are designed for experienced bicycle mechanics and must be followed exactly as written and specified. Failure to precisely follow these instructions could cause damage to one or more components of the Marzocchi suspension system. This damage may not be readily visible or apparent and could lead to unexpected failure on one or more components of your suspension to such extent that the rider may loose control of the bicycle and suffer severe injury.

**The responsibility of the owner**

- 1) The Marzocchi suspension system is designed to absorb the shocks of an uneven road surface in order to give the rider more control over this bicycle. It is not designed to absorb the forces generated by jumps or other acrobatic maneuvers. If you subject the Marzocchi suspension system to repeated jumps or other acrobatic maneuvers, you could cause one or more of the components of the suspension system to unexpectedly break, resulting in a loss of bicycle control and serious injury to the rider.
- 2) Some of the parts of the bicycle, such as the brakes, steering, tires, wheel assembly and shifters may not have been adjusted at the time the Marzocchi suspension system was installed on the bicycle. Before you ride the bicycle, be sure all the parts of the bicycle were properly adjusted and functioning properly.
- 3) All of the components of the suspension system must be correctly assembled and tightened exactly to the specified torque values. Periodically check the torque of these components to insure that they are correct. Failure to properly assemble and tighten the components could cause one or more of the components to unexpectedly break, resulting in a loss of bicycle control and serious injury to the rider.
- 4) There are obvious risks associated with mountain biking and other types of bicycle riding. Despite the use of all safety equipment for the bicycle and the rider, either injuries or damages may occur. This is the responsibility of the rider. To reduce the risk of injury, all activities must be under proper supervision and only after proper training and experience. Good physical condition of the rider and the good state of the bicycle are essential to be a safe and successful rider.
- 5) Be sure to read and follow all the instructions and warnings which originally accompanied your bicycle. In addition, it is recommended for added safety and protection while riding that a good quality bicycle helmet be worn and that other safety devices such as lights, reflectors, or reflective clothing be used. Some cities and states may require the use of a helmet and other safety equipment. Follow all traffic rules and all other laws about safety equipment and use your bicycle where you are permitted to ride.
- 6) For any further information you might need, please call or write to this addresses:

**LARM**

Via Ca' dell'Orbo, 36 -  
 40055 Villanova di Castenaso (Bologna) - Italy  
 ☎ ++51/6053460 - Fax ++51/6053411

**MSC CORPORATION USA**

28231 Avenue Crocker - Unit 100  
 VALENCIA CA, 91355  
 ☎ +1 (805) 257-6630 - Fax +1 (805) 257-6636

**It is your responsibility to make sure the assembly instructions in this book are precisely followed.**

**Always ride safely and carefully.**

**GENERAL**

- Spring pre-load adjustment controlled via external top mount adjusters.
- Oversized 30 mm stanchions and full length bushings for superior rigidity.
- Stanchions designed with a special safety feature to eliminate any chance of the stanchions becoming separated from the crown.
- Parts subjected to friction are cooled and lubricated by a specially formulated oil.
- Stanchion protections available on request.

**Steer tube:** in CrMo steel with variable butting. Several lengths available in threaded or non threaded 1 1/8" and 1 1/4" diameters.

**Crown:** Forged and CNC-machined BAM\* aluminum alloy.

**Arch:** cast aluminum alloy.

**Stanchions:** anodized EASTON aluminum with variable butting.

**Sliders:** Cast and CNC-machined aluminum alloy.

**Springs:** with variable pitch.

**Slider bushing:** Full length guide bushing composed of a copper base and impregnated with an anti-friction coating.

**Seals:** Computer designed oil seals guarantee the highest quality seals available.

**Oil:** Specially formulated oil which eliminates foaming and viscosity breakdown while providing complete stiction-free performance.

**Fork leg oil:** 65 cc type EBH 16 - SAE 7.5.

\* **BAM: Bomber Aerospace Material.**

Special alloy developed from aerospace material.

**The fork is supplied with:**

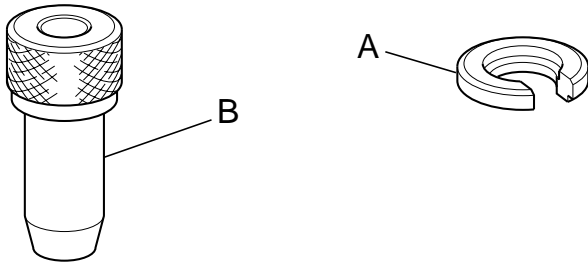
- Warranty card
- Owners manual
- Technical Specifications.

**Size:**

- travel: 65 mm (2.5 inches)
- crown to axle length: 430 mm
- stanchions outer diameter: 30 mm
- fork leg distance between centers: 130 mm
- cantilever boss distance between centers: 80 mm
- pilot bushing length: 92 mm

**SPECIFIC MARZOCCHI TOOLS**

Ref.	Item./Art.	Description and use
A	536003AB	Slider protector: to remove the oil seal from the slider
B	R 5068	Oil seal press: to press oil seal into the slider



**These are the specific tools necessary for an overhaul, you may find it necessary to use common tools found in your shop.**



## GENERAL RULES FOR CORRECT OVERHAULING AND MAINTENANCE

1. Where specified, assemble and disassemble the shock absorption system only using the LARM or MARZOCCHI special tools, as shown in the table below.
2. On reassembling the suspension system, always use new seals.
3. If two screws are close one to the other, always tighten using a 1-2-1 sequence. In short, screw the first screw just up to the point it is well tightened, then tighten the second screw and then go back to the first one and screw it tighter.
4. Clean all metal parts with a special, preferably biodegradable solvent, such as trichloroethane or trichloroethylene.
5. Before reassembling, lubricate all parts in contact with each other using silicone fat spray.
6. Always grease the conic seal rings before reassembling.
7. Use wrenches with metric size only. Wrenches with inch size might damage the fastening devices even when their size is similar to that of the wrenches in metric size.

## FAILURES, CAUSES AND REMEDIES

This paragraph reports some failures that may occur when using the fork. It also indicates possible causes and suggests a remedy. Always refer to this table before doing any repair work.

FAILURES	CAUSES	REMEDIES
Excessive oil build up on stanchions	<ol style="list-style-type: none"> <li>1. Oil seal is worn out</li> <li>2. Stanchion tube is scored</li> <li>3. Excessive dirt on oil seal</li> </ol>	<ol style="list-style-type: none"> <li>1. Replace oil seal</li> <li>2. Replace oil seal and stanchion tube</li> <li>3. Clean the oil seal seat and replace it</li> </ol>
Oil leaking through the bottom of slider	O-ring on the pumping rod screw is damaged	Replace the O-ring
Fork has not been used for some time and is locked out	Oil seals and dust seals tend to stick to stanchion tube	Raise dust seal and lubricate stanchion tube, dust seal and oil seal with silicone grease
Excessive play of stanchions in the sliders	Pilot bushings are worn	Replace pilot bushings

## RECOMMENDATIONS FOR MAINTENANCE

MARZOCCHI forks are based on advanced technology, supported by year-long experience in the field of professional mountain biking. In order to achieve best results, we recommend to check and clean the area below the oil seal and the stanchion tube after each use and lubricate with silicone oil.

## INSTALLATION

Installing the Z4 fork on a bicycle is a very delicate operation that should be carried out with extreme care. The installation should always be checked by one of our Technical Service Centers.



**WARNING:** Steer tube/headset mounting and adjustment must be carried out in compliance with the headset manufacturer's instructions either when a threaded steer tube or an "A-Head Set" steer tube is installed. Improper installation may jeopardize the safety of the rider. The steer tube is interchangeable in Z4 crown as it is secured to the crown by a clamp fastened with two screws. This allows the interchanging of different diameters by using special reduction bushes. Steer tubes should be changed following installation instructions completely. Be sure to install correct steer type (A-Head Set or threaded), diameter and length for the frame on which it should be fitted. If necessary check with one of our Technical Service Centers for proper fit.



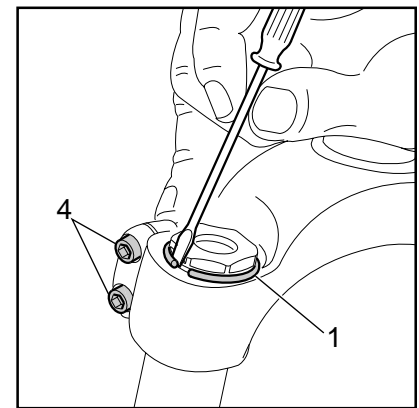
**WARNING:** In case of improper installation of the steer tube into the crown, the rider could lose control of his/her bicycle, thus jeopardizing his/her safety.

Check the torque of the bolts fastening the stanchions to the crown and attaching the brake arch to the sliders.  
For recommended torque settings, see the table below:

Thread diameter	Tightening torque	
	Nm	lb ft
M4	4	2.9
M5	9	6.6
M6	11	7.5

To remove the fork legs from the crown, loosen the bolts (4, FIG. A) and remove the safety ring (1, FIG. A). For easier removal, insert a small screwdriver between the ring and its seat and then remove the complete fork legs.

**⚠ WARNING:** Be sure to install the fork legs safety rings when reassembling, so that the fork legs do not become separated from the crown even though the bolts have become loose.

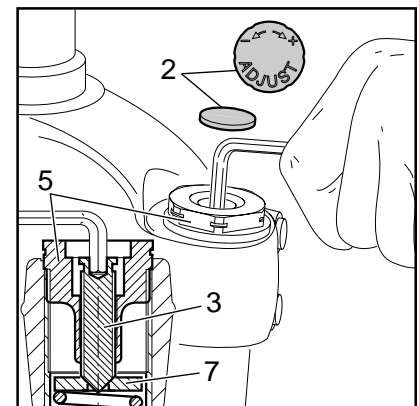


### SPRING PRELOAD ADJUSTMENT (FIG. B)

**⚠ IMPORTANT:** both fork legs should be adjusted on the same position.

Take off the rubber protection (2).  
To change preload, turn the screw (3) inside cap (5) using a 4 mm Allen wrench. Turn out the screw (3) completely, then turn it counterclockwise until it touches the upper washer (7). From this starting position, which corresponds to "0" preload, turn in as many turns as the preload you want. Each turn corresponds to 1.25 mm (0.05 in.).  
When supplied, Z4 is set with the minimum preload. However, springs are slightly preloaded to counteract static loads. By turning the adjustment screw clockwise, the preload is increased up to the maximum value equal to equal to 15 mm's of spring preload. This adjustment is essential in order to have the right Z4 response for the rider's weight and riding style.

FIG. B

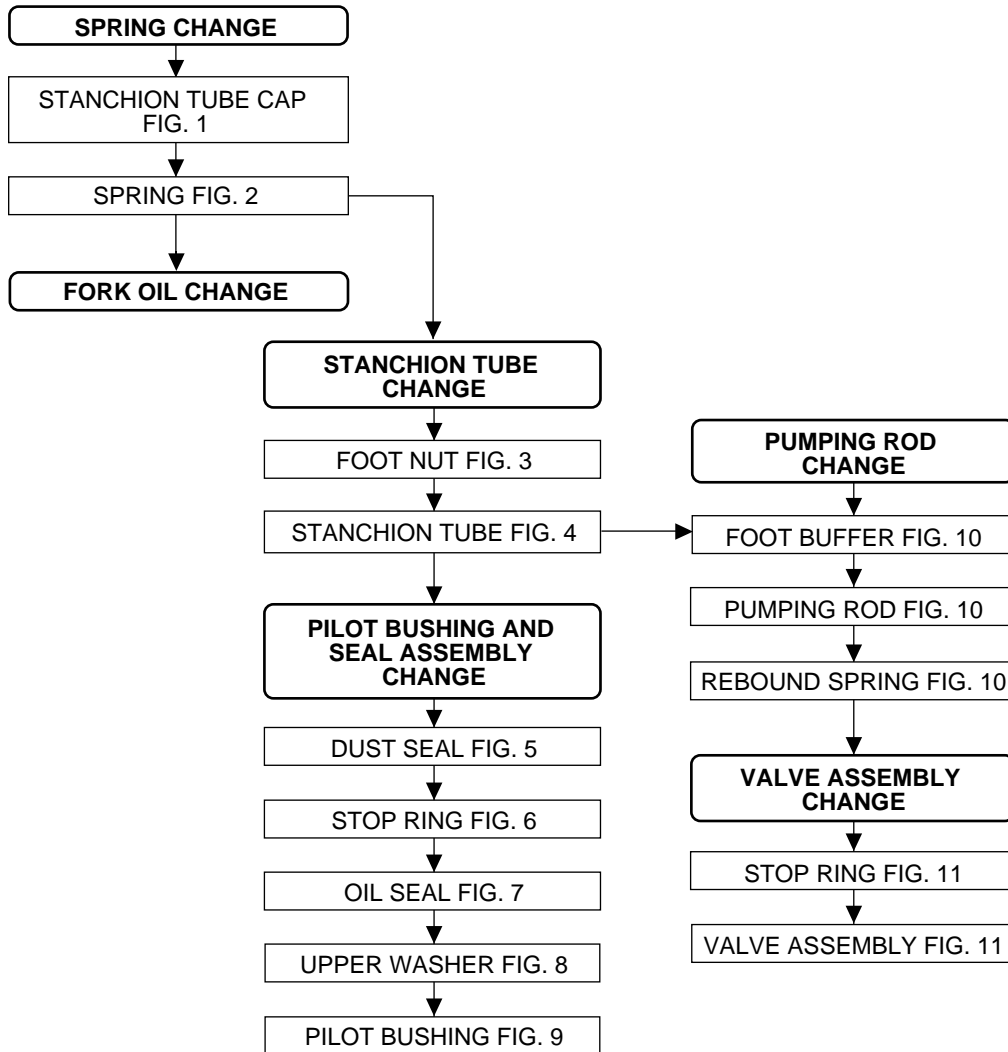


### DISASSEMBLY

#### GENERAL

- The reference numbers given in this section relate to the components shown in the fork exploded view on page 13.
- Operations refer to the fork legs already removed from the crown and disassembled from the brake arch.
- Before starting any operation, please read the diagram below. It shows the quickest procedure and the exact disassembling sequence. Locate the part you need to remove in the diagram, then look at the arrows to determine which other parts you will need to remove first.

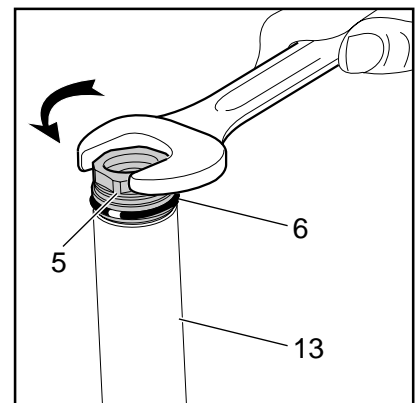
**DISASSEMBLY DIAGRAM**



**SPRING CHANGE  
FIG. 1**

Place the stanchion tube (13) in a vice making sure it is not damaged or dented in the process and unscrew the cap (5) with a 26 mm wrench. Remove the cap complete with O-ring (6) from the stanchion tube.

**FIG. 1**



**FIG. 2**

Push the stanchion tube into the slider and remove the spring (9).  
Let all the oil drain out.



**WARNING:** Remember to always recycle any used oil.

To change the fork leg oil follow the procedure as described in section  
"REASSEMBLY" from FIG. 22 to FIG. 24.

**PILOT BUSHING AND SEAL ASSEMBLY CHANGE**

**FIG. 3**

Turn the leg upside-down and place the slider in a vice with soft jaws.



**CAUTION:** tighten gently otherwise the slider may damage.

Unscrew the foot screw (22) with a 17 mm socket wrench.

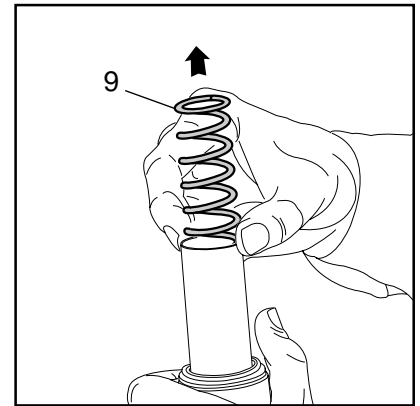
**FIG. 4**

Withdraw the stanchion tube (13) from the slider.

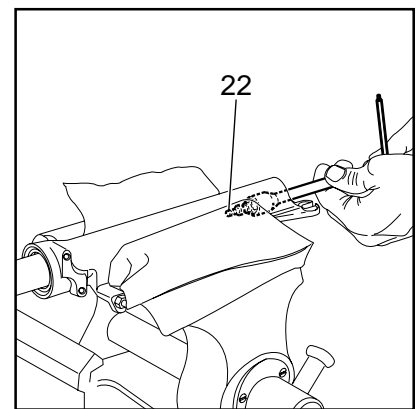
**FIG. 5**

Remove the dust seal (14) from the top of the slider using a small  
screwdriver.

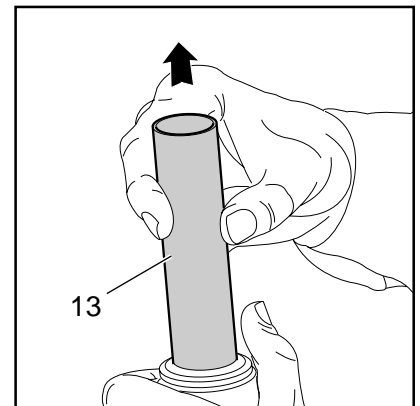
**FIG. 2**



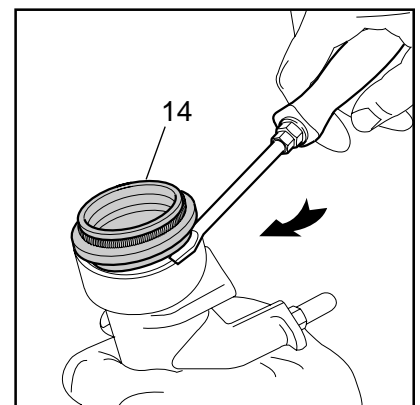
**FIG. 3**



**FIG. 4**



**FIG. 5**

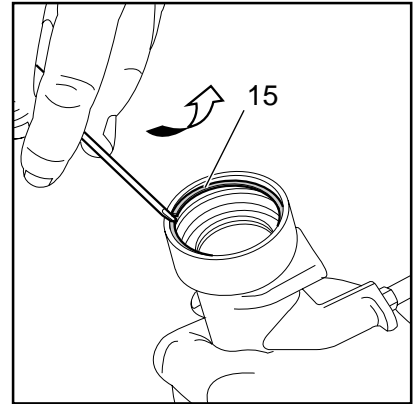




**FIG. 6**  
Remove the stop ring (15) from the slider by placing the screwdriver bit in one of the three openings on the stop ring.

**⚠ IMPORTANT:** when removing the stop ring, make sure not to damage its seat.

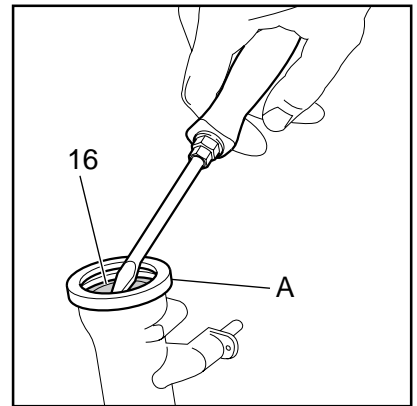
**FIG. 6**



**FIG. 7**  
Fit the slider protector (A) onto the slider and remove the oil seal (16) with the help of a large screwdriver.

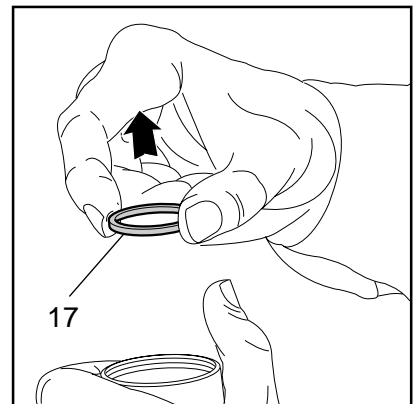
**⚠ IMPORTANT:** when removing the oil seal, make sure not to damage its seat. Once removed the oil seals should not be used again.

**FIG. 7**



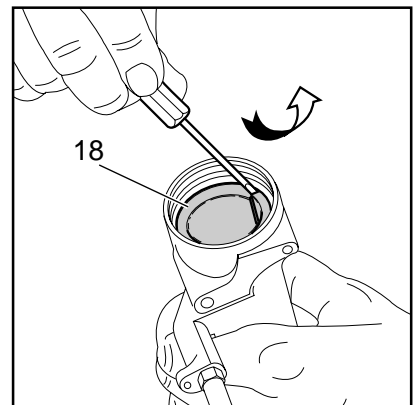
**FIG. 8**  
Remove the upper washer (17) from the slider.

**FIG. 8**



**FIG. 9**  
Fit the bit of a small screwdriver into the upper edge slot of the pilot bushing (18) and lift gently. Pull the bushing out of the slider and make all necessary changes.

**FIG. 9**



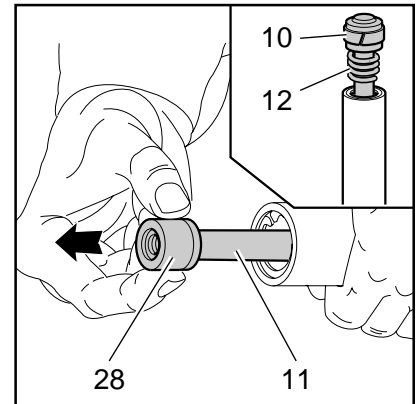


### PUMPING ROD CHANGE

**FIG. 10**

Remove the foot buffer (28) from the pumping rod (11) end. Withdraw the pumping rod (11) and the rebound spring (12) from the stanchion tube opposite side. Replace the seal ring (10) if damaged or worn out.

**FIG. 10**

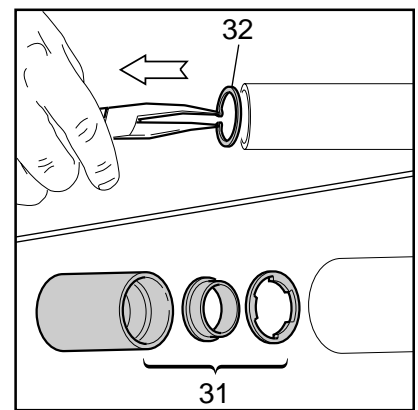


### VALVE ASSEMBLY CHANGE

**FIG. 11**

To check that the valve unit is operating correctly, it is necessary to work on the inside of the stanchion tube. Slip off the stop ring (32) using pointed pliers. Pull the valve assembly (31) out of the tube in the same sequence as in the figure.

**FIG. 11**



### REASSEMBLY



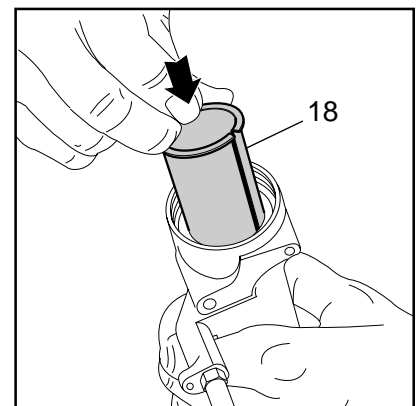
**CAUTION:** before reassembling, all metal parts should be washed carefully with inflammable, preferably biodegradable, solvent and dried with compressed air.

### PILOT BUSHING AND SEAL ASSEMBLY

**FIG. 12**

Check that no dirt or debris is between slider and bushing. Insert the pilot bushing (18) into place so that it adheres to the slider.

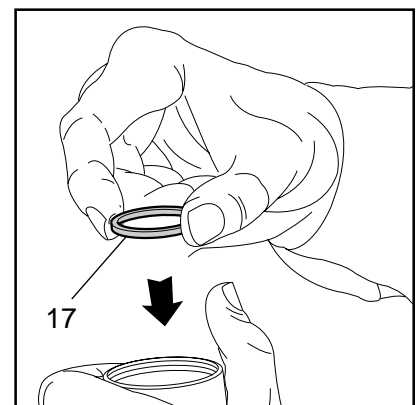
**FIG. 12**



**FIG. 13**

Fit the upper washer (17) into the slider so that it touches the pilot bushing.

**FIG. 13**

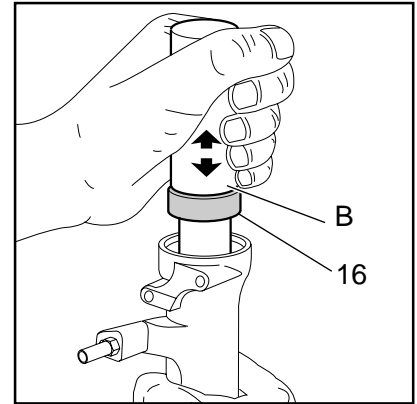




**FIG. 14**

Lubricate the oil seal (16) and fit it onto the seal press (B) with the hollow side toward the slider.  
Press the oil seal until it touches the upper washer by using the above seal press.

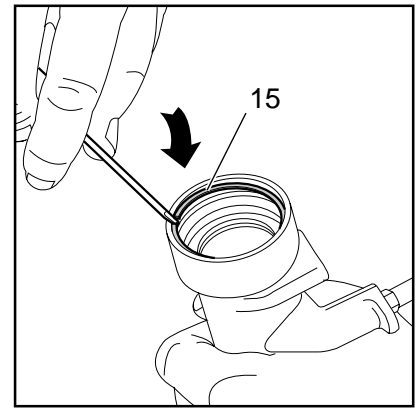
**FIG. 14**



**FIG. 15**

Insert the stop ring (15) making sure it is properly seated into place.

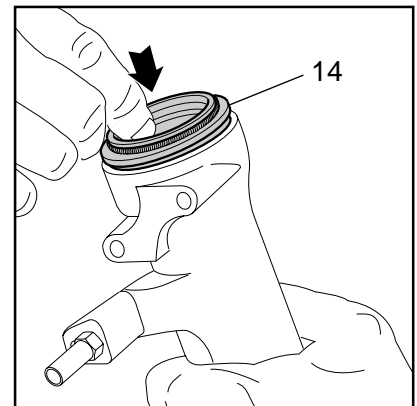
**FIG. 15**



**FIG. 16**

Lubricate the dust seal (14) and fit it onto the top of the slider.

**FIG. 16**

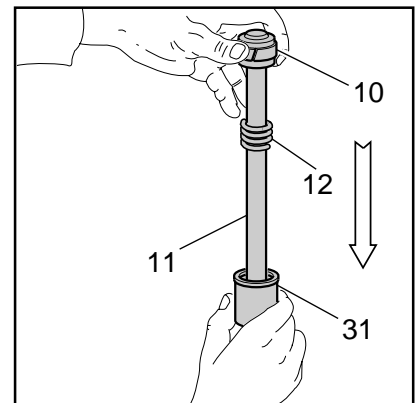


**VALVE AND PUMPING ROD ASSEMBLY**

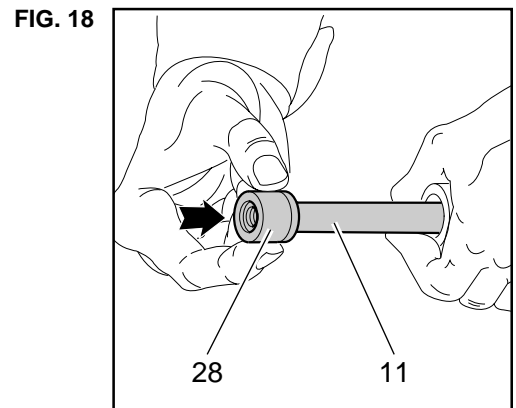
**FIG. 17**

After having overhauled or replaced the valve assembly and after having cleaned the inside of the tube, reassemble. Assemble valve components (31), in correct sequence.  
Then fit pumping rod (11), seal ring (10) and rebound spring (12) into the valve assembly (31) and push it until it comes out from the other end.

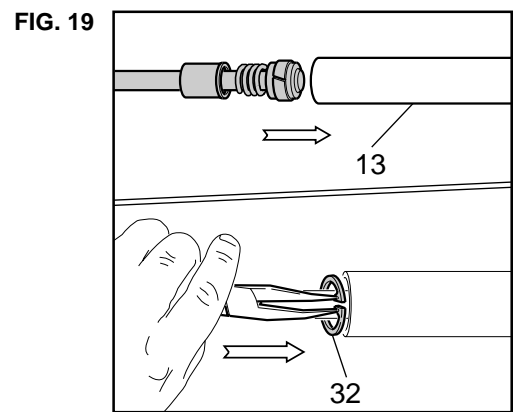
**FIG. 17**



**FIG. 18**  
Reassemble the foot buffer (28) onto the end part of pumping rod (11).

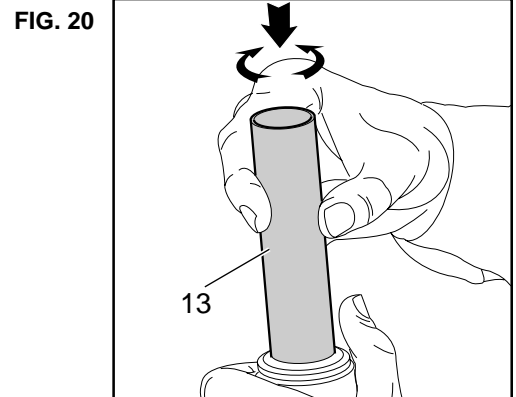


**FIG. 19**  
Fit this assembly into the stanchion tube (13) and properly seat the valve assembly (31). Insert the stop ring (32).

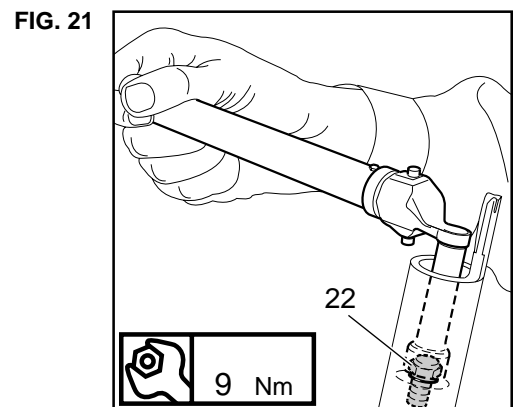


**STANCHION TUBE ASSEMBLY**

**FIG. 20**  
Fit the stanchion tube (13) gently into the dust seal (14). Rotate the stanchion tube while inserting it into the seal to facilitate installation and reduce the chance of damaging the seals. Turn the slider over and check that the foot buffer hole is aligned with the slider hole.



**FIG. 21**  
Clamp the slider in a vice with soft jaws and tighten the screw (22) at 9 Nm with a 17 mm wrench. Check to see that the stanchion tube slides unrestricted by cycling the fork up and down several times. The tube should slide freely inside the seal assembly without any side play. In the event it is too hard or too soft, repeat the previous steps described above checking to ensure that components are not damaged.



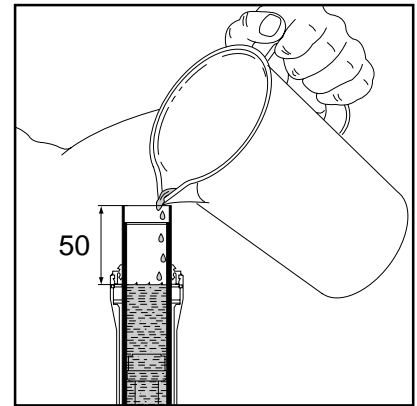


## HOW TO FILL WITH OIL

**FIG. 22**

Pour the oil little by little when the stanchion tube is fully down and then pump the stanchion tube so as to have a better filling. Check that the oil level is 50 mm/1.96 in. from the top of the stanchion tube, in both legs.

**FIG. 22**

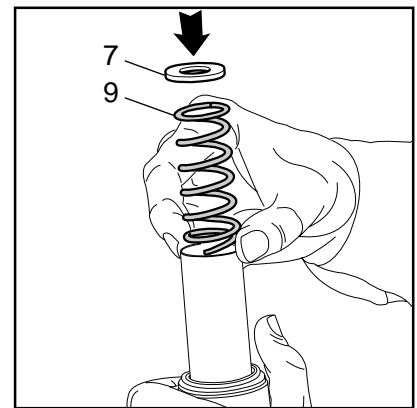


## SPRING AND PRELOAD CAP ASSEMBLY

**FIG. 23**

Fit the spring (9) into the stanchion tube.  
Install the upper washer (7).

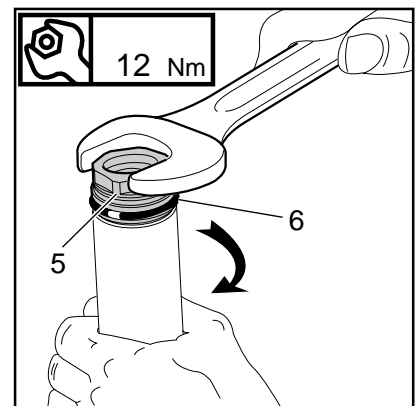
**FIG. 23**



**FIG. 24**

Lubricate the O-ring (6) on the preload cap (5). Turn the preload screw (3) counterclockwise until it is at its minimum setting. Fit the complete cap assembly into the stanchion tube by hand. Place the stanchion tube in a vice. Be sure it is not damaged or dented in the process and tighten the cap (5) at 12 Nm. Set spring preload as specified in the chapter "SPRING PRELOAD ADJUSTMENT".  
At this point the brake arch can be installed on the fork leg, which should then be installed into the crown as specified in SECTION "INSTALLATION".

**FIG. 24**



### FORK EXPLODED VIEW

**Ref. Description**

- 1 Safety ring
- 2 Protection
- 3 Preload screw
- 4 Screw
- 5 Cap
- 6 O-ring
- 7 External preload adjuster
- 8 Crown with steer tube
- 9 Spring
- 10 Ring
- 11 Pumping rod
- 12 Rebound spring
- 13 Stanchion tube
- 14 Dust seal
- 15 Stop ring
- 16 Oil seal
- 17 Upper washer
- 18 Pilot bushing
- 19 R.H. slider
- 20 L.H. slider
- 21 O-ring
- 22 Foot screw
- 23 Cantilever boss
- 24 Arch
- 25 Screw
- 26 Crown
- 27 Steer tube
- 28 Foot buffer
- 29 R.H. sticker
- 30 L.H. sticker
- 31 Valve assembly
- 32 Stop ring

